

NORTH DAKOTA STATE PLUMBING BOARD



*Laws, Rules, and Plumbing
Installation Standards of
North Dakota.*

2009 Uniform Plumbing Code

*Effective April 1, 2010
Revised 2014*

FORWARD

Adoption of the State Plumbing Law was an act to promote and protect the public health through the regulations of the business of plumbing; creating a State Board of Plumbing and empowering said Board and State Department of Health to adopt rules governing the practice of plumbing and establishing a code of minimum standards of plumbing work; providing for the licensing and regulation of plumbers and the regulation, supervision and inspection of plumbing work; providing concurrent authority for cities and villages; and fixing penalties.

The installation of plumbing is a matter concerning the public health. Hence, but with one purpose in mind, to insure that the construction, installation and maintenance of plumbing in buildings in the state shall be safe, sanitary, and such as to safeguard the public health, the following rules governing the installation of plumbing are adopted.

The State Plumbing Law carries no legislative appropriation. Salaries of inspectors, employees, expenses of board members, office supplies, printing costs, stationery, stamps, etc., must be defrayed by the State Plumbing Board Fund which is derived principally by monies obtained from license fees and plumbing installation certificates. For this reason the printing and distribution of the code falls in a slightly different category than most state publications and, because of very limited income, general distribution is impossible.

INTERPRETIVE RULES. Some of the details of plumbing construction may vary, but the basic sanitary and safety principles desirable and necessary to protect the health of the people are the same everywhere. As interpretations may be required and as unforeseen situations arise which are not specifically covered in the code, the following principles must be used to define the intent of this code.

1. **ALL OCCUPIED PREMISES MUST HAVE POTABLE WATER.** All premises intended for human habitation, occupancy, or use must be provided with a supply of potable water. Such a water supply must not be connected with unsafe water sources, nor be subject to the hazards of backflow.
2. **ADEQUATE WATER REQUIRED.** Plumbing fixtures, devices, and appurtenances must be supplied with water in sufficient volume and at pressures adequate to enable them to function properly and without undue noise under normal conditions of use.
3. **HOT WATER REQUIRED.** Hot water must be supplied to all plumbing fixtures that normally need or require hot water for their proper use and function.
4. **WATER CONSERVATION.** Plumbing must be designed and adjusted to use the minimum quantity of water consistent with proper performance and cleaning.
5. **SAFETY DEVICES.** Devices for heating and storing water must be so designed and installed as to guard against dangers from explosion or overheating.
6. **USE PUBLIC SEWER WHERE AVAILABLE.** Every building with installed plumbing fixtures and intended for human habitation, occupancy, or use, and located on premises where a public sewer is on or passes said premises within two hundred feet, must be connected to the sewer.
7. **REQUIRED PLUMBING FIXTURES.** Each family dwelling unit must have at least one water closet, one lavatory, one kitchen-type sink, and one bathtub or shower to meet the basic requirements of sanitation and personal hygiene. All other structures for human habitation must be equipped with sufficient sanitary facilities. Plumbing fixtures must be made of durable, smooth, nonabsorbent, and corrosion-resistant material and must be free from concealed fouling surfaces.
8. **DRAINAGE SYSTEM.** The drainage system must be designed, constructed, and maintained to guard against fouling, deposit of solids, and clogging, and with adequate cleanouts so arranged that the pipes may be readily cleaned.
9. **DURABLE MATERIALS AND GOOD WORKMANSHIP.** The piping of the plumbing system must be of durable material, free from defective workmanship, and so designed and constructed as to give satisfactory service for its reasonably expected life.
10. **FIXTURE TRAPS.** Each fixture directly connected to the drainage system must be equipped with a liquid seal trap.

11. **TRAP SEALS MUST BE PROTECTED.** The drainage system must be designed to provide an adequate circulation of air in all pipes with no danger of siphonage, aspiration, or forcing of trap seals under conditions of ordinary use.
12. **EXHAUST FOUL AIR TO OUTSIDE.** Each vent terminal must extend to the outer air and be so installed as to minimize the possibilities of clogging and the return of foul air to the building.
13. **TEST THE PLUMBING SYSTEM.** The plumbing system must be subjected to such tests as will effectively disclose all leaks and defects in the work or the material.
14. **EXCLUDE CERTAIN SUBSTANCES FROM THE PLUMBING SYSTEM.** A substance that will clog or accentuate clogging of pipes, produce explosive mixtures, destroy the pipes or their joints, or interfere unduly with the sewage disposal process must not be allowed to enter the building drainage system.
15. **PREVENT CONTAMINATION.** Proper protection must be provided to prevent contamination of food, water, sterile goods, and similar materials by backflow of sewage. When necessary, the fixture, device, or appliance must be connected indirectly with the building drainage system.
16. **LIGHT AND VENTILATION.** A water closet or similar fixture must not be located in a room or compartment that is not properly lighted and ventilated.
17. **INDIVIDUAL SEWAGE DISPOSAL SYSTEM.** If water closets or other plumbing fixtures are installed in buildings where there is no sewer within a reasonable distance, suitable provision must be made for disposing of the sewage by some accepted method of sewage treatment and disposal.
18. **PREVENT SEWER FLOODING.** Where a plumbing drainage system is subject to backflow of sewage from the public sewer or private disposal system, suitable provision must be made to prevent its overflow in the building.
19. **PROPER MAINTENANCE.** Plumbing systems must be maintained in a safe and serviceable condition from the standpoint of both mechanics and health.
20. **FIXTURES MUST BE ACCESSIBLE.** All plumbing fixtures must be so installed with regard to spacing as to be accessible for their intended use and for cleaning.
21. **STRUCTURAL SAFETY.** Plumbing must be installed with due regard to preservation of the strength of structural members and prevention of damage to walls and other surfaces through fixture usage.
22. **PROTECT GROUND AND SURFACE WATER.** Sewage or other waste must not be discharged into surface or subsurface water unless it has first been subjected to some acceptable form of treatment.

TABLE OF CONTENTS

North Dakota State Plumbing Law (North Dakota Century Code)

Chapter 43-18	Plumbers	1
Chapter 43-18.1	Water Conditioning Contractors and Installers	7
Chapter 43-18.2	Sewer and Water Installers	9

North Dakota Administrative Code Title 62

Article 62-01 General Administration

Chapter 62-01-01	Organization of Board	11
------------------	-----------------------	----

Article 62-02 Licensure

Chapter 62-02-01	Plumber Licensure	13
Chapter 62-02-02	Water Conditioning Contractor and Installer Licensure	17
Chapter 62-02-03	Sewer and Water Contractor and Installer Licensure	20

Article 62-03.1 Plumbing Installation Standards

Chapter 62-03.1-01	Administration	22
Chapter 62-03.1-02	General Regulations Table 2902.1 Minimum Number of Required Plumbing Fixtures	24 29
Chapter 62-03.1-03	Private Sewage Disposal Systems	34

Useful Information		52
---------------------------	--	-----------

CHAPTER 43-18 PLUMBERS

43-18-01. Definitions. In this chapter, unless the context or subject matter otherwise requires:

1. "Board" means the state board of plumbing.
2. "Journeyman plumber" means any person, other than a master plumber, who, as the person's principal occupation, is engaged in the practical installation, alteration, and repair of plumbing.
3. "Master plumber" means a person skilled in the planning, supervision, and the practical installation, alteration, and repair of plumbing, and familiar with the laws, rules, and regulations governing the same.
4. "Plumber's apprentice" means any person other than a journeyman or a master plumber, who, as the person's principal occupation, is engaged in learning and assisting in the installation, alteration, and repair of plumbing and drainage, under the immediate and personal supervision of either a master or a journeyman plumber.
5. "Plumbing" means the installation, maintenance, extension, alteration, and removal of all piping, plumbing fixtures, plumbing appliances, and other appurtenances in connection with bringing water into, and using the same in buildings, and for removing liquids and water-carried wastes therefrom.

43-18-02. State board of plumbing - Members - Appointment - Qualifications. The state board of plumbing shall consist of the chief sanitary engineer, or the head of any division of the state department of health who may be named by the chief sanitary engineer to act in the chief sanitary engineer's stead, and four persons appointed by the governor. All of the appointed members must have been residents of this state for at least five years immediately preceding their appointment, and one of them must be a master plumber with at least five years of experience in North Dakota, one must be a journeyman plumber with at least five years of experience in North Dakota, one must be a registered professional engineer practicing mechanical engineering in North Dakota, and one must be a representative of the consuming public.

43-18-03. State board of plumbing - Members - Terms of office - Vacancies - How filled. Each appointed member of the board shall qualify by taking the oath of office required of civil officers and shall hold office for a term of four years and until a successor is appointed and qualified. The terms of office of the appointed members must be so arranged that one term only expires on the thirtieth day of June of each year. The four members appointed by the governor to the first board must be appointed within thirty days after July 1, 1975, to serve for the following terms: one master plumber for one year, one journeyman plumber for two years, one mechanical engineer for three years, and a representative of the consuming public for four years. A vacancy on the board caused by the death, resignation, or expiration of the term of any appointed member must be filled for the unexpired term by appointment by the governor from the class of members to which the deceased or retiring member belonged.

43-18-04. Office and officers of board. The members of the board shall elect from their number a president, a vice president, and a treasurer, and they shall select a secretary, but the office of secretary and treasurer may be held by the same person. The secretary or secretary-treasurer need not be a member of the board but must be a licensed plumber. The board shall have its headquarters at the state capital.

43-18-05. Members of board and employees - Compensation. Each appointed member of the board is entitled to receive compensation in an amount determined by the board,

not to exceed one hundred dollars per day, for actual services rendered in the performance of the member's duties under this chapter, and each member and employee of the board is entitled to receive traveling expenses incurred in the performance of official duties. Allowances for traveling expenses must be as provided by law for state officials and employees. The compensation and expense must be paid out of the state plumbing board fund. The compensation provided for in this section may not be paid to any member of the board who receives salary or other compensation as a regular employee of the state or any of its political subdivisions or any institution or industry operated by the state.

43-18-06. Board may hire and fix compensation of employees - Incur necessary expenses. The board may employ inspectors, who must be registered plumbers, and such stenographers and assistants, as may be necessary, and shall fix the compensation of such employees, and may incur such other expenses as may be required. All such salaries and expenses must be paid only out of such moneys as may be in the state plumbing board fund.

43-18-07. Fees - Where deposited - Use. Repealed by S.L. 1971, ch. 510, § 15.

43-18-08. Duties of board. The board shall:

1. Enforce the provisions of this chapter.
2. Prescribe rules and regulations not inconsistent with the provisions of this chapter for the examination, regulation, and licensing of plumbers, either as master plumbers, journeyman plumbers, plumber's apprentices, or any of such classifications.

43-18-09. Board to adopt plumbing code - Provisions have force of law. The board shall formulate, prepare, and circulate among all plumbers within this state a state plumbing code, which must contain the minimum basic standards for plumbing, drainage, and ventilation of plumbing in buildings of all classes. Such code must be approved by the state department of health. The provisions of said code have the force and effect of law and any violation thereof constitutes a violation of this chapter.

43-18-10. Firm engaged in installing plumbing to employ master plumber - Exceptions. No person, firm, corporation, or limited liability company shall engage in the business of installing plumbing and shall not install plumbing in connection with the dealing in and selling of plumbing materials and supplies in any location of this state having a public system of waterworks or sewerage, unless at all times a registered and licensed master plumber, who is responsible for the proper installation thereof, is in charge of such work. In cities of less than one thousand population and in all rural areas, a licensed journeyman plumber may engage in the business of installing plumbing.

43-18-11. License required - Exception for homeowner and full-time employee. No person, firm, corporation, or limited liability company shall engage in the business of a master plumber, journeyman plumber, or plumber's apprentice in any location of this state having a public system of waterworks or sewerage unless registered and licensed to do so by the board. Anyone not so licensed may do plumbing work which complies with the provisions of the minimum standards prescribed by the board on premises or that part of premises owned and actually occupied by the person as a residence, or may do plumbing repair on premises where the person is employed in full-time maintenance work, unless otherwise forbidden to do so by a local ordinance. Public water system employees may install and maintain service lines and water meters on premises served by the water system.

43-18-11.1. When license not required. Employees of dealers in household appliances need not be licensed pursuant to this chapter when installing household appliances, if any necessary plumbing work is incidental to the installation of the appliance and the work could be performed by a plumber's apprentice.

43-18-11.2. Conviction not bar to licensure - Exceptions. Conviction of an offense does not disqualify a person from licensure under this chapter unless the board determines that

the offense has a direct bearing upon a person's ability to serve the public as a plumber, or that, following conviction of any offense, the person is not sufficiently rehabilitated under section 12.1-33-02.1.

43-18-11.3. Advertising prohibited - Exceptions - Penalty.

1. Except as provided in this section, if a plumbing license is required under section 43-18-11 or by local ordinance, no person offering plumbing contracting services may advertise as a plumbing contractor, master plumber, or journeyman plumber unless the person employs a licensed journeyman plumber, or the person is a licensed master plumber. Any advertisement must contain the appropriate license number. This section does not apply to advertising purchased or contracted for prior to July 1, 1989.
2.
 - a. A person violating this section is guilty of a class B misdemeanor for a first conviction, but no fine in excess of one hundred dollars and no term of imprisonment may be imposed.
 - b. A person violating this section is guilty of a class A misdemeanor for a second or subsequent conviction, but the penalties are as follows:
 - (1) For a second conviction, no fine in excess of one thousand dollars and no term of imprisonment may be imposed.
 - (2) For a third or subsequent conviction, a fine not to exceed one thousand dollars or imprisonment not to exceed thirty days, or both, may be imposed.

43-18-11.4. Plumbing inspectors - License required - Exception. A person employed by the state board of plumbing or a political subdivision to inspect plumbing installations must be licensed as a journeyman or master plumber. This section does not apply to an inspector employed by the board of plumbing or a political subdivision as of July 2, 1989.

43-18-12. Examination - When held - Notice. Examinations must be held at the time and place prescribed by the board. Notice of such examinations must be given by mail to all persons who have made application to take the examination. The board may call a special examination at any time.

43-18-13. License - How obtained - Fee. Any person qualified under the rules of the board who desires to take the examination to become a registered and licensed plumber shall make application to the board therefor and pay to the treasurer of the board the examination fee. Such fee may not exceed two hundred dollars for a master plumber's certificate and license and one hundred dollars for a journeyman plumber's certificate and license. The board, when the condition of its fund permits and when in its judgment it is deemed advisable, may reduce the amount of the examination fees, but it may not increase the same above the amount specified in this section. Any such change must be adopted by the board to take effect on the first day of January following its action and must apply to all examination fees in the classes specified in the ruling. The applicant shall appear at the next regular meeting of the board for examination of applicants. If upon examination the applicant is found by the board to be qualified as a master plumber or journeyman plumber, or both, it shall issue to the applicant a certificate of registration and license which entitles the applicant to do the work and be a plumber as specified in the license. A master plumber's and journeyman plumber's license may be issued to one and the same person, and the holder of a master plumber's license may be granted a journeyman plumber's license without the payment of the journeyman's fee. All certificates and licenses must be numbered consecutively and may not be transferable, and no person may work under the license issued to another person. Should a person fail upon examination to qualify as a master or journeyman plumber, such person has the right to review the examination to determine the reasons for failure and has the right to appeal to the board.

43-18-13.1. Reciprocity with other states. The board may register, without examination, upon payment of the required fee, nonresident applicants registered under the laws of other states having requirements for regulating plumbers which the board determines are substantially equivalent to the requirements of this state in those instances when such other state grants similar privileges to North Dakota residents licensed under this chapter.

43-18-14. Board to keep register of licenses issued. The board shall keep a register in which must be entered the names and addresses of all persons to whom certificates of registration and license are issued under the provisions of this chapter as master plumbers, and also a register in which must be entered the names and addresses of all persons to whom certificates of registration and license are issued under the provisions of this chapter as journeyman plumbers. Such register must be open to the public for inspection.

43-18-15. Temporary license - When issued. The board, upon the payment of the regular examination fee, may issue a temporary permit to engage in the business of master plumber or journeyman plumber, or both, to any person who furnishes satisfactory evidence of the person's qualifications. Such permits are revocable permits and are effective to December thirty-first of the year in which they are issued. No person may be issued such temporary permits for longer than four years.

43-18-16. Plumber licensed by board may practice at any place in state - Exception. A plumber registered and licensed by the board to engage in the business of master plumber, journeyman plumber, or plumber's apprentice may engage in or work at the business of plumbing at any place in this state, except in cities that have adopted ordinances requiring a municipal license or registration in addition to the state license before permitting any plumber to work in such municipality.

43-18-17. Renewal of license - Fee. A certificate and license issued under the provisions of this chapter is valid for only one year and expires on the thirty-first day of December of the year in which it was issued. The certificate must be renewed by the board upon application made within thirty days after the expiration thereof and on the payment of a sum not to exceed two hundred dollars for a master plumber's certificate and license, and the sum of one hundred dollars for a journeyman plumber's certificate and license. The board, when the condition of its fund permits and when in its judgment it is deemed advisable, may reduce the amount of the renewal fees, but it may not increase the same above the amount specified in this section. Any such change must be adopted by the board to take effect on the first day of January following its action and applies to all renewals in the classes specified in the ruling.

43-18-17.1. Continuing education. After January 1, 1991, each applicant for renewal of a master or journeyman plumber's license under section 43-18-17 must have successfully completed prior thereto at least two credit hours, and thereafter a minimum of two credit hours and not to exceed four credit hours within a two-year period, of continuing education relating to the plumbing trade.

Credit hours for educational sessions must be determined by the board on a continuing basis to evaluate new sessions as they become available for fulfilling the educational requirements of this section. The board may charge a fee sufficient to offset expenses incurred for any educational sessions for which it is directly responsible.

43-18-17.2. Report of work - Exception. A person shall report doing plumbing work subject to inspection under section 43-18-17.3 to the board upon forms furnished by the board. This section does not apply to plumbing installations in buildings that are not connected to a public system of waterworks or sewerage or in political subdivisions where inspection is required by local ordinance.

43-18-17.3. Inspection of installation - Exception. The board has jurisdiction over and shall make provision for inspection of plumbing installations or alterations to public buildings and installations in newly constructed dwelling units, except as provided in this section. Political subdivisions may provide for inspection of plumbing work done within their jurisdictional limits.

The board may charge the person responsible for the installation a reasonable fee not to exceed the cost of inspection. No inspection is required for any repair work or plumbing fixture replacement which requires only minor alteration, or to buildings that are not connected to a public system of waterworks or sewerage, and does not apply to maintenance work conducted by regularly employed maintenance personnel on the business premises of their employer.

43-18-18. Grounds for revocation of license. The board may revoke any certificate issued under the provisions of this chapter if the holder is guilty of:

1. Commission of an offense determined by the board to have a direct bearing upon the holder's ability to serve the public as a plumber, or the board determines, following conviction of any offense, that the holder is not sufficiently rehabilitated under section 12.1-33-02.1;
2. Error or fraud in obtaining the holder's certificate;
3. Permitting the use of the holder's certificate and license in violation of this chapter;
4. Incompetency;
5. Failure to furnish certification of completion of continuing education as required under section 43-18-17.1; or
6. Failure to report work as required under section 43-18-17.2.

43-18-19. Revocation - Hearing. A certificate of registration and license issued under the provisions of this chapter may be revoked only after a hearing of the charges by the board. The holder of the certificate must be notified in writing by the board of the charges against the holder and of the time and place fixed for the hearing. Such notice must be served by registered or certified mail, addressed to the post-office address of the certificate holder as shown in the holder's certificate of registration and license. The time set for the hearing must be not less than ten days after the service of the notice. The hearing must be public and full opportunity must be given the accused to produce witnesses and evidence in the accused's own behalf and to examine the witnesses against the accused. After hearing all the evidence, the board shall render its decision in writing and the accused must be furnished, by mail, a copy thereof. If the accused is found guilty of any offense for which revocation of the license is provided, the certificate of registration and license is revoked automatically.

43-18-20. Revocation of license - When reinstated. A person whose certificate of registration and license issued under the provisions of this chapter has been revoked by the board may not be permitted to apply for a license for a period of one year from the date of the revocation. After the expiration of such time, the board may consider an application for reinstatement of such person and upon a showing that the disability has been removed or that there is no further likelihood that the offense will be repeated, the board may reinstate the license.

43-18-21. Apprenticeship. Every apprentice plumber shall, within thirty days after beginning apprenticeship, register with the state plumbing board on a registration application form which will be supplied by the board, showing date of beginning apprenticeship, age, schooling, previous experience, employer, and such other information as the board may require, except that a person who is working in a school-work program need not register. A registration certificate issued under the provisions of this section shall be valid for only one year and shall expire on the thirty-first day of December of the year in which it was issued. The certificate shall be renewed by the board upon application made within thirty days after the expiration thereof and on payment of the sum set by the board, but not to exceed twenty dollars for the first year, thirty dollars for the second year, forty dollars for the third year, and fifty dollars for the fourth year of apprenticeship. The fee after a four-year term of apprenticeship is the same as the fee for a journeyman plumber. This certificate of registration shall be the license required to be employed as a plumber's apprentice in this state.

43-18-22. Local authorities report violations to board. Such local authority as may be designated by an ordinance of the municipality to issue plumbing permits and licenses, and to approve plumbing plans, shall report to the board willful violations of the state plumbing code and of any municipal ordinances regulating the same, and any incompetence on the part of any registered and licensed plumber that comes to the attention of the local authority.

43-18-23. Working as plumber without license. It is unlawful for any person to work, for compensation, as a master plumber, journeyman plumber, or plumber's apprentice without being registered and licensed as a plumber in such classification.

43-18-24. Violation of chapter - Penalty. Any person that violates the state plumbing code adopted under section 43-18-09; violates section 43-18-10, 43-18-11, 43-18-11.4, 43-18-17.2, or 43-18-23; or works under the license of another person in a manner that is in violation of section 43-18-13 is guilty of a class B misdemeanor.

43-18-25. Injunction. In addition to the criminal penalty provided in section 43-18-24, the civil remedy of injunction is available to plumbing inspectors to restrain and enjoin violations of any provisions of this chapter. Any person claiming to be injured in person or property because of violations of this chapter may bring a civil action for damages.

CHAPTER 43-18.1

WATER CONDITIONING CONTRACTORS AND INSTALLERS

43-18.1-01. Definitions. In this chapter, unless the context or subject matter otherwise requires:

1. "Board" means the state board of plumbing.
2. "Water conditioning contractor" means a person who plans and manages the installation and repair of water conditioning equipment, and in conjunction therewith sells or leases such equipment.
3. "Water conditioning installation and repair" means the installation of appliances, appurtenances, and fixtures designed to treat water so as to alter, modify, add or remove mineral, chemical, or bacterial content, and the repair of such equipment, to a water distribution system. "Water conditioning installation and repair" does not mean the exchange of such appliances, appurtenances, and fixtures when the plumbing system has previously been installed or adapted to or for such appliances, appurtenances, and fixtures, and no substantial change in such plumbing system is required.
4. "Water conditioning installer" means any person who is engaged in the practical installation and repair of water conditioning equipment.

43-18.1-02. Administration. All fees and money obtained by the board through the administration of this chapter must be used for the regulation of the business of water conditioning installation and repair, through the board, and all such fees and money are appropriated to the board for such purpose. This appropriation is a continuing appropriation of all such sums. The handling and administration of such fees and money must otherwise be in accordance with section 54-44-12.

43-18.1-03. Duties of the board. The board shall:

1. Enforce the provisions of this chapter.
2. Prescribe rules and regulations not inconsistent with the provisions of this chapter for the examination, regulation, and licensing of water conditioning contractors and water conditioning installers.

43-18.1-04. Licenses - Examination - Fees - Apprentices.

1. No person, firm, corporation, or limited liability company, except plumbers holding valid licenses pursuant to chapter 43-18, shall engage in the business of water conditioning contractor or water conditioning installer in any incorporated city of this state having a system of waterworks or sewage unless registered and licensed to do so by the board. Installation and repair of water conditioning equipment shall be done by the person holding a water conditioning installer's license.
2. The board shall hold not less than one public meeting per year for the purpose of examination of persons who may desire to become registered and licensed in the water conditioning business pursuant to this chapter. Notice and time of such examination shall otherwise be in accordance with section 43-18-12 and the examination provided for herein may be held in conjunction with the examination provided for in chapter 43-18.
3. Examination for licenses and registration shall be upon application as prescribed by the board and payment of the examination fee. Such fee shall be forty dollars and twenty dollars for registration and licensure as a water conditioning contractor and

water conditioning installer, respectively. If the holder of an installer's license is also a contractor, the fee shall be forty dollars. The examination shall be as prescribed by the board but shall be limited to the installation and repair of water conditioning equipment as such relates to plumbing. The issuance of licenses and registrations hereunder shall be as prescribed by the board which shall be guided in such actions by the provisions of section 43-18-13.

4. An apprentice may be employed by any licensee under this chapter. When so employed the apprentice shall perform the apprentice's employment under the direct supervision of the licensee and when engaged in installation or repair pursuant to this chapter the apprentice shall be under the direct supervision of a licensed installer. Upon employment and termination of employment the name of the apprentice and the apprentice's employer shall be communicated to the board.

43-18.1-05. Temporary licenses - Issuance. The board, upon payment of the fees provided in this chapter, shall issue special temporary permits to engage in water conditioning installation and repair as provided in this chapter to those applicants who furnish sufficient proof that they were engaged in such business on January 1, 1973. Such special temporary permits are retroactive to January 1, 1973, and expire thirty days after the date the second examination as provided under section 43-18.1-04 is given, but no later than July 1, 1974. The board may prescribe rules and regulations under which regular temporary permits may be issued which must be generally in accordance with section 43-18-15.

43-18.1-05.1. Conviction not bar to licensure - Exceptions. Conviction of an offense does not disqualify a person from licensure under this chapter unless the board determines that the offense has a direct bearing upon a person's ability to serve the public as a water conditioning contractor, or that, following conviction of any offense, the person is not sufficiently rehabilitated under section 12.1-33-02.1.

43-18.1-06. Renewal of license and registration - Fee. Except for special temporary licenses as provided in this chapter, a license issued under this chapter is valid for only one year and expires on December thirty-first of the year in which it was issued. The license must be renewed by the board upon application made within thirty days after the expiration thereof and on the payment of the fees as provided in section 43-18.1-04.

43-18.1-07. Revocation of licenses. The board may revoke any license issued under the provisions of this chapter if the licensee has:

1. Committed an offense determined by the board to have a direct bearing upon a holder's ability to serve the public as a water conditioning contractor, or the board determines, following conviction of any offense, that a holder is not sufficiently rehabilitated under section 12.1-33-02.1;
2. Committed a fraud in obtaining the holder's certificate;
3. Permitted the use of the holder's license in violation of this chapter; or
4. Performed work or business in an incompetent manner.

43-18.1-08. Revocation - Hearing - Reinstatement. A license issued under the provisions of this chapter may be revoked only upon a charge in writing filed with the board and after a hearing thereon by the board. Such hearing must be conducted in accordance with the procedures set forth in section 43-18-19. Reinstatement of a license revoked under this chapter may be made in accordance with section 43-18-20.

43-18.1-09. Violations - Penalty. Any person that violates the state plumbing code adopted under section 43-18-09, violates subsection 1 of section 43-18.1-04, or works under the license of another person in a manner that is in violation of subsection 3 of section 43-18.1-04 is guilty of a class B misdemeanor.

CHAPTER 43-18.2 SEWER AND WATER INSTALLERS

43-18.2-01. Definitions. In this chapter, unless the context or subject matter otherwise requires:

1. "Board" means the state board of plumbing.
2. "Sewer and water contractor" means any person who installs, plans, and manages the installation and repair of building sewer and water service.
3. "Sewer and water installation" means the installation of building sewer and water service and the repair of existing building sewer and water service.
4. "Sewer and water installer" means any person, other than a sewer and water contractor, who installs and repairs building sewer and water service.

43-18.2-02. Duties of the board. The board shall:

1. Enforce this chapter.
2. Adopt rules not inconsistent with this chapter for the examination, regulation, and licensing of sewer and water contractors and sewer and water installers.
3. Exempt from the provisions of sections 43-18.2-06, 43-18.2-07, and 43-18.2-08 those North Dakota sewer and water contractors and installers as defined in section 43-18.2-01 who have at least one year's work experience prior to July 1, 1987.

43-18.2-03. Licenses. No person, firm, corporation, or limited liability company, except plumbers holding valid licenses under chapter 43-18, may engage in the business of sewer and water contractor or sewer and water installer unless registered and licensed by the board to do so. This license allows the licensee to do plumbing necessary for sewer and water installation.

43-18.2-04. Sewer and water installer apprentice license. All applicants for a building sewer and water installer apprentice license shall complete an application identifying the building sewer and water installer under whose supervision the applicant is working. The license is without charge for two years and must be renewed annually.

43-18.2-05. Out-of-state applicants. An applicant for a sewer and water contractor's license or a sewer and water installer's license from out of state may take the examination upon showing by affidavits that the applicant has experience in the state in which the applicant is licensed. This experience must be the same as is required of applicants from this state. The board shall provide applicants with application forms and affidavit forms necessary to comply with this section. The secretary-treasurer of the board shall investigate the validity of the affidavits. A rejected application must be treated as an adjudicative proceeding.

43-18.2-06. Experience for testing. An applicant for a sewer and water installer's license shall show evidence of two years' experience as a building sewer and water installer apprentice in this state. Applicants for a sewer and water installation contractor's license must have one year's experience as an installer in this state. All applicants shall show that their work complies with the state plumbing code. Proof of experience must be shown by affidavits which the board may investigate. The board shall provide applicants with application forms. If the application is rejected, the matter must be treated as an adjudicative proceeding.

43-18.2-07. Examination requirements. The examination for applicants for licensure must consist of:

1. Questions pertaining to the application and maintenance of basic principles of sewer and water installation.
2. Questions which require the application of the state plumbing code and the state industrial safety code to building sewer and water installation.

The questions for the sewer and water contractor and the building sewer and water installer need not be the same. The passing grade for the building sewer and water contractor must be eighty percent, and the sewer and water installer's passing grade must be seventy percent.

43-18.2-08. Examination fees. An applicant for a sewer and water contractor's license shall pay an examination fee of one hundred dollars, and an applicant for a building sewer and water installer's license shall pay an examination fee of twenty-five dollars before taking the examination for the first time. The reexamination fee is fifty dollars for a sewer and water contractor's license and ten dollars for a sewer and water installer's license. No additional fee may be charged for the first year of licensure. No applicant may be examined for the same license more often than every three months.

43-18.2-09. License renewal fees. The license renewal fee for a sewer and water contractor after the first year of licensure may not exceed one hundred dollars per year, and the license renewal fee for a sewer and water installer after the first year of licensure may not exceed twenty-five dollars per year. The license renewal fee for a sewer and water installer apprentice after the first two years of licensure is twenty-five dollars.

43-18.2-10. Revocation of licenses. The board may revoke any license issued under this chapter if the licensee has:

1. Committed an offense, as defined by section 12.1-01-04, determined by the board to have a direct bearing upon a holder's ability to serve the public as a sewer and water contractor, sewer and water installer, or a sewer and water installer apprentice, or the board determines, following conviction of any offense, that a holder is not sufficiently rehabilitated under section 12.1-33-02.1;
2. Committed a fraud in obtaining the license;
3. Permitted the use of the license in violation of this chapter; or
4. Performed work or business in an incompetent manner as determined by the board.

43-18.2-11. Administration of funds - Continuing appropriation. All fees and moneys obtained by the board through the administration of this chapter must be used for the regulation of the business of sewer and water installation and repair, and are appropriated to the board for this use. This appropriation is a continuing appropriation of all such funds. The handling and administration of the funds must otherwise be in accordance with section 54-44-12.

43-18.2-12. Violation - Penalty. Any person that violates the state plumbing code adopted under section 43-18-09, violates section 43-18.2-03, or works under the license of another person in a manner that is in violation of section 43-18.2-06 is guilty of a class B misdemeanor.

ARTICLE 62-01

GENERAL ADMINISTRATION

Chapter
62-01-01 Organization of Board

CHAPTER 62-01-01 ORGANIZATION OF BOARD

Section
62-01-01-01 Organization of Board of Plumbing

62-01-01-01. Organization of board of plumbing.

1. **History.** The 1941 legislative assembly passed a state plumbing law, codified as North Dakota Century Code chapter 43-18. The chapter was intended to promote and protect the public health through the regulation of the business of plumbing by creating a state board of plumbing and empowering the board and the state department of health to adopt rules governing the practice of plumbing and establishing a code of minimum standards of plumbing work. The 1973 legislative assembly passed legislation, codified as North Dakota Century Code chapter 43-18.1, which regulates the installation of water-conditioning equipment. The 1987 legislative assembly passed legislation, codified as North Dakota Century Code chapter 43-18.2, which regulates the installation of sewer and water services.
2. **Board membership.** The board of plumbing consists of the chief sanitary engineer of the state department of health, and four persons appointed by the governor: one a master plumber; one a journeyman plumber; one a registered professional engineer; and one a representative of the consuming public. The four appointed members of the board serve four-year terms, with one term expiring each year.
3. **Secretary and chief inspector.** The secretary and chief inspector of the board is appointed by the board and is responsible for administration of the board's activities.

4. **Inquiries.** All inquiries and communication relating to licensing, plumbing installation, and inspections may be directed to:

North Dakota State Plumbing Board
1110 College Drive, Suite 210
Bismarck, ND 58501

Phone (701) 328-9977
Fax (701) 328-9979
E-mail ndplumb@nd.gov

History: Amended effective November 1, 1981; September 1, 1987; April 1, 1994; March 1, 2000; April 1, 2010.

General Authority: NDCC 28-32-02.1

Law Implemented: NDCC 28-32-02.1

ARTICLE 62-02

LICENSURE

Chapter	
62-02-01	Plumber Licensure
62-02-02	Water Conditioning Contractor and Installer Licensure
62-02-03	Sewer and Water Contractor and Installer Licensure

CHAPTER 62-02-01 PLUMBER LICENSURE

Section	
62-02-01-01	Application for Journeyman or Master Plumber License
62-02-01-01.1	Application for Apprentice Plumber - Supervised Practice
62-02-01-02	Examination Fee for Each Examination
62-02-01-03	Examination Subjects and Passing Grades
62-02-01-04	Reexamination
62-02-01-05	Reexamination of Apprentice Plumber
62-02-01-06	Master Plumber - Renewal of Journeyman and Master Plumber Certificate
62-02-01-07	Renewal of Expired License
62-02-01-08	Application for Plumbing Installation Certificate [Repealed]
62-02-01-09	Licensed Master Plumber Required [Repealed]

62-02-01-01. Application for journeyman or master plumber license.

No applicant shall be entitled to take the examination for either the master or journeyman plumber's certificate and license unless and until the applicant furnishes to the board satisfactory evidence that the applicant possesses sufficient practical experience to enable the applicant to perform satisfactorily the duties of the classification for which the applicant has made application.

1. Applicants for a journeyman plumber's examination and license shall have had four years' experience as an apprentice plumber under a licensed master plumber. Applicants who are working at the plumbing trade in localities where state licenses are not required, who have had five years of experience (one thousand nine hundred hours per year and a total of nine thousand five hundred hours) and who furnish four affidavits verifying years of experience, may make application for a journeyman examination screening test. The screening test is defined as an oral and written test given by the state plumbing board and a plumbing inspection report, signed by a state plumbing inspector, of an installation installed by the applicant to determine the applicant's qualifications for writing the journeyman examination.
2. Applicants who are journeyman plumbers in other states who desire to work in this state in localities where a state journeyman license is required may make application for a journeyman examination and license. Proof of such journeyman license from another state shall

be vouched for as provided on the application blank furnished by the North Dakota state plumbing board.

3. All applicants for a master plumber's license must be twenty-one years of age and must have had two years' (three thousand four hundred hours) experience as a journeyman plumber licensed by the state of North Dakota or any other state that has a state licensing law. Proof of such journeyman license from another state shall be vouched for as provided on the application blank furnished by the North Dakota state plumbing board.
4. Applicants who are master plumbers in other states who desire to work in this state in localities where a state master license is required may make application for a master examination and license. Proof of such master license from another state shall be vouched for as provided on the application blank furnished by the North Dakota state plumbing board.
5. All applications will expire and be canceled after a period of six months from date of approval if the applicant fails to appear for examination within the six-month period.

History: Amended effective February 1, 1994.

General Authority: NDCC 43-18-08

Law Implemented: NDCC 43-18-13, 43-18-13.1

62-02-01-01.1. Application for apprentice plumber - Supervised practice. An applicant for registration as an apprentice must have reached the age of eighteen years. An apprentice shall serve a term of four years, not less than one thousand nine hundred hours per year, with a total of not less than seven thousand six hundred hours.

1. The board may grant hourly credit toward a term of apprenticeship when the applicant furnishes proof of previous practical experience in the trade, or is a graduate of a course in plumbing at an accredited school having at least a nine month, one thousand twenty hours course in plumbing. The number of hours credit for each hour of the course according to the graduating grade average shall be: A average - two hours, B average - one and three-quarter hours, C average - one and one-half hours, and a D average - one hour. Credit for trade-related experience shall be determined by criteria established by the board.
2. A master plumber employing a registered apprentice shall report to the board any changes made in relation to continued employment of such apprentice. It is the employer's duty and responsibility to not permit an apprentice to perform work unless under the direct supervision and in the immediate presence of either a master or journeyman plumber. There shall not be more than five plumber's apprentices under the immediate and personal supervision of either a master plumber or

journeyman plumber employed on any installation, alteration, or repair project.

3. Apprentice plumbers who have had three years (five thousand seven hundred hours) experience in learning and assisting in the installation, alteration, and repair of plumbing, and working for a master plumber, may work during their fourth year of apprenticeship by themselves without being under the direct supervision of a master or journeyman plumber.

History: Effective February 1, 1994.

General Authority: NDCC 43-18-08

Law Implemented: NDCC 43-18-21

62-02-01-02. Examination fee for each examination. An applicant for examination shall be entitled to one examination only for each examination fee paid.

General Authority: NDCC 43-18-08

Law Implemented: NDCC 43-18-13

62-02-01-03. Examination subjects and passing grades. Examination for applicants desiring to become registered and licensed plumbers shall consist of: answering questions pertaining to the basic principles of plumbing and the plumbing code; preparing drawings on which the applicant is to draw all stacks, wastes, and vents, and to insert the minimum pipe sizes. The examinations for master and journeyman plumber need not be the same. The passing grade for a master plumber shall be eighty percent, and the journeyman plumber passing grade shall be seventy percent.

General Authority: NDCC 43-18-08

Law Implemented: NDCC 43-18-08, 43-18-13

62-02-01-04. Reexamination. If an applicant fails to pass an examination, the applicant shall be denied the right to take another examination until at least six months shall have passed from the date of the applicant's last examination.

General Authority: NDCC 43-18-08

Law Implemented: NDCC 43-18-13

62-02-01-05. Reexamination of apprentice plumber. An apprentice plumber who has written and failed the journeyman examination must rewrite the examination at the end of the six-month period or work under direct supervision of a licensed master or journeyman plumber.

General Authority: NDCC 43-18-08

Law Implemented: NDCC 43-18-21

62-02-01-06. Master plumber - Renewal of journeyman and master plumber certificate. The holder of a master plumber's certificate and license

may renew the holder's journeyman certificate and license upon payment of the journeyman renewal fee and during the same year may reinstate the holder's master plumber's certificate and license upon payment of the difference between the journeyman renewal fee and the master renewal fee.

General Authority: NDCC 43-18-08

Law Implemented: NDCC 43-18-17

62-02-01-07. Renewal of expired license. No certificate and license need be renewed by the board later than one year subsequent to its expiration. The board may, in its discretion, require that a holder of a license which has been expired for one year or more submit to a new examination.

General Authority: NDCC 43-18-08

Law Implemented: NDCC 43-18-17

62-02-01-08. Application for plumbing installation certificate. Repealed effective March 1, 2000.

62-02-01-09. Licensed master plumber required. Repealed effective February 1, 1994.

CHAPTER 62-02-02
WATER CONDITIONING CONTRACTOR AND INSTALLER LICENSURE

Section	
62-02-02-01	Application for Water Conditioning Installer or Contractor License
62-02-02-02	Examination Fee for Each Examination
62-02-02-03	Examination Subjects and Passing Grades
62-02-02-04	Reexamination
62-02-02-05	Reexamination of Apprentice Water Conditioning Installer
62-02-02-06	Water Conditioning Contractor - Renewal of Installer and Contractor Certificate
62-02-02-07	Renewal of Expired License
62-02-02-08	Issuance of Water Conditioning Installer's Certificate and License
62-02-02-09	Report of Water Conditioning Equipment Installation

62-02-02-01. Application for water conditioning installer or contractor license. No applicant shall be entitled to take the examination for either the water conditioning contractor or water conditioning installer's certificate and license unless and until the applicant furnishes to the board satisfactory evidence that the applicant possesses sufficient practical experience to enable the applicant to perform satisfactorily the duties of the classification for which the applicant has made application.

1. Applicants for a water conditioning installer's examination and license shall have had one year's experience as an apprentice water conditioning installer under a licensed water conditioning contractor. A one-year term of apprenticeship is defined as not less than one thousand nine hundred hours.
2. Applicants who are water conditioning installers in other states who desire to work in this state in localities where a state water conditioning installer's license is required may make application for a water conditioning installer's examination and license. Proof of such water conditioning installer's license from another state shall be vouched for as provided on the application blank furnished by the plumbing board.
3. Graduates of the plumbing course of an accredited trade school having at least a nine-month (one thousand twenty hours) course in plumbing shall be eligible to make application for a water conditioning installer's examination and license.
4. All applicants for a water conditioning contractor's license must be twenty-one years of age and must have had one year's (one thousand nine hundred hours) experience as a water conditioning installer licensed by the state of North Dakota or any other state that has a state licensing law. Proof of such water conditioning installer's license from

another state shall be vouched for as provided on the application blank furnished by the plumbing board.

5. Applicants who are water conditioning contractors in other states who desire to work in this state in localities where a state water conditioning contractor's license is required may make application for a water conditioning contractor's examination and license. Proof of such water conditioning contractor's license from another state shall be vouched for as provided on the application blank furnished by the plumbing board.
6. All applications will expire and be canceled after a period of six months from date of approval if the applicant fails to appear for examination within the six-month period.

History: Amended effective October 1, 1989.

General Authority: NDCC 43-18.1-03

Law Implemented: NDCC 43-18.1-04

62-02-02-02. Examination fee for each examination. An applicant for examination shall be entitled to one examination only for each examination fee paid.

General Authority: NDCC 43-18.1-03

Law Implemented: NDCC 43-18.1-04

62-02-02-03. Examination subjects and passing grades. Examination for applicants desiring to become registered and licensed water conditioning contractors or water conditioning installers shall consist of answering questions pertaining to the basic principles of the code and questions which are based upon the code. The questions for water conditioning contractors and water conditioning installers need not be the same. The passing grade for a water conditioning contractor shall be eighty percent, and the water conditioning installer passing grade shall be seventy percent.

General Authority: NDCC 43-18.1-03

Law Implemented: NDCC 43-18.1-04

62-02-02-04. Reexamination. If an applicant failed to pass an examination, the applicant shall be denied the right to take another examination until at least six months shall have passed from the date of the applicant's last examination.

General Authority: NDCC 43-18.1-03

Law Implemented: NDCC 43-18.1-04

62-02-02-05. Reexamination of apprentice water conditioning installer. An apprentice water conditioning installer who has written and failed the water conditioning installer's examination must rewrite the examination at the end of

the six-month period or work under the direct supervision of a licensed water conditioning contractor or water conditioning installer.

General Authority: NDCC 43-18.1-03

Law Implemented: NDCC 43-18.1-04

62-02-02-06. Water conditioning contractor - Renewal of installer and contractor certificate. The holder of a water conditioning contractor's certificate and license may renew the holder's water conditioning installer's certificate and license upon payment of the twenty dollar fee and during the same year may reinstate the holder's water conditioning contractor's certificate and license upon payment of an additional twenty dollars.

General Authority: NDCC 43-18.1-03

Law Implemented: NDCC 43-18.1-06

62-02-02-07. Renewal of expired license. No certificate and license need be renewed by the board later than one year subsequent to its expiration. The board may, in its discretion, require that a holder of a license which has been expired for one year or more submit to a new examination.

General Authority: NDCC 43-18.1-03

Law Implemented: NDCC 43-18.1-06

62-02-02-08. Issuance of water conditioning installer's certificate and license. The board issues a person a water conditioning installer's certificate and license upon and with the understanding that the holder thereof shall not engage in the business of installing water conditioners unless at all times a registered and licensed water conditioning contractor, who is responsible for the proper installation of the water conditioners, is in charge of such work.

General Authority: NDCC 43-18.1-03

Law Implemented: NDCC 43-18.1-04

62-02-02-09. Report of water conditioning equipment installation. It shall be the duty of water conditioning contractors to report to the plumbing board office all installations of water conditioning equipment in localities that do not enforce a permit and inspection program for the installation of water conditioning equipment.

General Authority: NDCC 43-18.1-03

Law Implemented: NDCC 43-18.1-03

CHAPTER 62-02-03
SEWER AND WATER CONTRACTOR AND INSTALLER LICENSURE

Section	
62-02-03-01	Application for Sewer and Water Installer or Contractor License
62-02-03-02	Examination Fee for Each Examination
62-02-03-03	Reexamination of Apprentice Sewer and Water Installer
62-02-03-04	Renewal of Expired License
62-02-03-05	Renewal of Sewer and Water Contractor and Installer Certificate and License
62-02-03-06	License Renewal

62-02-03-01. Application for sewer and water installer or contractor license. No applicant is entitled to take the examination for either the sewer and water contractor or sewer and water installer's certificate and license unless and until the applicant furnishes to the board proof that the applicant possesses sufficient practical experience to enable the applicant to perform satisfactorily the duties of the classification for which the applicant has made application. If the applicant fails to appear for examination, the application will expire after a period of six months from date of verification of the application. The board will consider the following as sufficient practical experience.

1. A one-year term of practical experience is defined as one thousand seven hundred hours.
2. Graduates of a plumbing course of an accredited trade school having at least a nine-month (one thousand twenty hours) course in plumbing shall satisfy the apprentice requirements and be eligible to make application for a sewer and water installer's examination and license.
3. Apprentice plumbers registered with this state and having two years' experience are eligible to make application for a sewer and water installers examination and license. A one-year term of apprenticeship is defined as not less than one thousand seven hundred hours.

History: Effective September 1, 1987.

General Authority: NDCC 43-18.2-02(2)

Law Implemented: NDCC 43-18.2-02(3)

62-02-03-02. Examination fee for each examination. An applicant for examination is entitled to one examination only for each examination fee paid.

History: Effective September 1, 1987.

General Authority: NDCC 43-18.2-02

Law Implemented: NDCC 43-18.2-08

62-02-03-03. Reexamination of apprentice sewer and water installer. An apprentice sewer and water installer who has written and failed the sewer and water

installer's examination must rewrite the examination at the end of a three-month period. During the three-month period the sewer and water installer apprentice may work under the direct supervision of a licensed sewer and water installer.

History: Effective September 1, 1987.

General Authority: NDCC 43-18.2-02

Law Implemented: NDCC 43-18.2-04

62-02-03-04. Renewal of expired license. Any person may renew his license without examination if renewal occurs within one year following expiration. The board shall require that a holder of a license which has been expired for one year or more submit to a new examination.

History: Effective September 1, 1987.

General Authority: NDCC 43-18.2-02

Law Implemented: NDCC 43-18.2-09

62-02-03-05. Renewal of sewer and water contractor and installer certificate and license. The holder of a sewer and water contractor's certificate and license may renew the sewer and water installer's certificate and license upon payment of the installer's renewal fee and during the same year may reinstate the holder's contractor's certificate and license upon payment of the difference between the installer and contractor renewal fee.

History: Effective January 1, 1992.

General Authority: NDCC 43-18.2-02

Law Implemented: NDCC 43-18.2-09

62-02-03-06. License renewal. A certificate and license issued under the provisions of this chapter is valid for not more than one year, beginning the first day of July and expiring on the thirtieth day of June of the following year.

History: Effective February 1, 1996.

General Authority: NDCC 43-18.2-02

Law Implemented: NDCC 43-18.2-09

ARTICLE 62-03.1

PLUMBING INSTALLATION STANDARDS

Chapter	
62-03.1-01	Administration
62-03.1-02	General Regulations
62-03.1-03	Private Sewage Disposal Systems

CHAPTER 62-03.1-01 ADMINISTRATION

Section	
62-03.1-01-01	Conformance With Uniform Plumbing Code - Exceptions
62-03.1-01-02	General Statement of Policy
62-03.1-01-03	Interpretive Rules [Repealed]
62-03.1-01-04	Administrative Powers and Duties
62-03.1-01-05	Application for Plumbing Installation Certificate

62-03.1-01-01. Conformance with Uniform Plumbing Code - Exceptions.

1. State plumbing code defined. The board adopts, as the state plumbing code, the 2009 edition of the Uniform Plumbing Code, including appendices A, B, D, E, I, and L, published by the international association of plumbing and mechanical officials, with the exceptions and modifications described in section 62-03.1-02-02 and chapter 62-03.1-03.
2. All plumbing as defined in North Dakota Century Code section 43-18-01, including materials, must meet or exceed the minimum provisions of this article and the Uniform Plumbing Code.

History: Effective March 1, 2000; amended effective April 1, 2010.

General Authority: NDCC 43-18-09

Law Implemented: NDCC 43-18-09

62-03.1-01-02. General statement of policy. The scope of this code excludes the development of specific standards related to any, all, or any combination of the composition, dimensions, or mechanical and physical properties of materials, fixtures, devices, and equipment used or installed in plumbing systems. The inclusion of a material, even though indicated as approved for purposes of the code, does not infer unqualified endorsement as to its selection of serviceability in any or every installation. The establishment of trade jurisdictional areas is not within the scope of this code.

History: Effective March 1, 2000.

General Authority: NDCC 43-18-09

Law Implemented: NDCC 43-18-09

62-03.1-01-03. Interpretive rules. Repealed effective April 1, 2010.

62-03.1-01-04. Administrative powers and duties. The secretary-chief inspector and other inspectors of the North Dakota state plumbing board, under the direction of the board, shall administer laws, rules, plumbing installation standards of this state, and the Uniform Plumbing Code. In all cases when any action is taken by the secretary-chief inspector or inspectors of the board to enforce the provisions of any sections contained in this article or the Uniform Plumbing Code, such acts must be done in the name of and on behalf of the state.

History: Effective March 1, 2000.

General Authority: NDCC 43-18-09

Law Implemented: NDCC 43-18-09

62-03.1-01-05. Application for plumbing installation certificate. Any plumbing installation requiring inspection must have a plumbing installation certificate properly executed by the master or journeyman plumber in charge of the installation. The board shall have on hand a supply of certificates for distribution to the person in charge of the installation.

1. Inspection fees for each certificate issued must be according to the schedule of fees shown on the plumbing installation certificate. If work has commenced prior to submittal of the certificate and proper fees, the fee will be double or actual cost incurred to investigate, whichever is less. Requested inspection, reinspection, or inspection for which no fee is specifically indicated must be charged at fifty dollars per hour, plus travel expense.
2. The certificate must be signed by the applicant and the original returned to the board along with the proper fees prior to commencement of work. The duplicate copy must be retained by the plumbing contractor and the triplicate copy must be submitted to the building owner. The issuing certificate fee must be charged for each certificate that must be reissued.

History: Effective March 1, 2000; amended effective April 1, 2010.

General Authority: NDCC 43-18-08

Law Implemented: NDCC 43-18-17.2, 43-18-17.3

CHAPTER 62-03.1-02 GENERAL REGULATIONS

Section

62-03.1-02-01

Conformance With Other Regulations

62-03.1-02-02

Uniform Plumbing Code - Exceptions and Modifications

62-03.1-02-01. Conformance with other regulations. Nothing in this article may be construed to prevent the application of local ordinances or other legal requirements.

History: Effective March 1, 2000.

General Authority: NDCC 43-18-09

Law Implemented: NDCC 43-18-09

62-03.1-02-02. Uniform Plumbing Code - Exceptions and modifications. The following chapters and appendices of the Uniform Plumbing Code are modified as follows:

1. **Administration.** Add to 101.5.6 the words "or within" after the word "into". The following subsections do not apply: 103.1 through 103.4; 103.5.1.2, 103.5.3.1, 103.5.6, and table 1-1.
2. **Definitions.** Add to 211.0: "Inspection report" means a notice, written by a plumbing inspector to the person responsible for the plumbing installation, describing work inspected and stating violations and noncompliance of rules and regulations as listed, which must be corrected within a designated time.

Add to 218.0: "Plumbing installation certificate" means a document consisting of one or more copies certifying that certain plumbing installations, plumbing fixtures, plumbing appliances, and other appurtenances were installed in conformity with the rules and regulations of the plumbing board. "Permit" as used in the Uniform Plumbing Code has the same meaning as plumbing installation certificate.

"Plumbing" add to definition: Maintenance does not include making repairs to faucets, valves, appliances, and fixtures, or removal of stoppages in waste or drainage pipes. See also North Dakota Century Code section 43-18-01.

"Plumbing system": Not included in this definition are medical gas and medical vacuum systems, liquid and fuel gas piping, and vents for water heaters.

3. **General regulations.** Add to 313.2: When a water heater is located in an attic, attic-ceiling assembly, floor-ceiling assembly, or floor-subfloor assembly where damage results from a leaking water heater, a

watertight pan of corrosion-resistant materials shall be installed beneath the water heater with not less than three-quarters of an inch [19.05 millimeters] diameter drain to an approved location. Add to 313.6: Water service piping must be installed with a minimum earth cover of seven feet [2.13 meters]. Minimum earth cover for building sewers must be four feet [1.22 meters].

Subsection 313.12.4 does not apply.

4. **Plumbing fixtures and fixture fittings.** Add to 402.4: Mixing-type hand-closing faucets may be installed on lavatories for public use. Lavatories must have waste outlets not less than one and one-fourth inches [31.75 millimeters] in diameter, with open strainers.

Add to 405.2: Urinals with nonintegral traps shall be prohibited.

Add to 408.1: Water closets in private rooms of hotels, motels, dormitories, and boarding houses must be of the elongated bowl type.

Delete table 4-1 from 412.1 and add table 2902.1 of the most recently state-adopted International Building Code, with the following modifications: References on table 2902.1 to sections of the International Building Code and International Plumbing Code do not apply.

Add to Note a: Types of occupancies not shown on this table shall be considered individually by the administrative authority. The occupant load shall be composed of fifty percent of each sex.

Add the following notes:

Drinking fountains. There shall be a minimum of one drinking fountain per occupied floor in schools, theaters, auditoriums, dormitories, and businesses. Where food is consumed indoors, water stations may be substituted for drinking fountains. Where bottled water coolers are provided, drinking fountains shall not be required. Drinking fountains shall not be required in occupancies with less than thirty persons. Drinking fountains shall not be installed in toilet rooms.

Urinals. The provision of urinals may offset water closets otherwise required but the number of water closets required may not be reduced in this manner by more than fifty percent. Walls and floors within two feet [609.6 millimeters] of the sides and front of urinals must be finished with a smooth, hard, nonabsorbent finish.

Lavatories. Where circular or similar handwashing appliances are provided, twenty-four lineal inches [609.6 millimeters] of wash sink or eighteen inches [457.2 millimeters] of a circular basin, when provided

with water outlets for such space, shall be considered equivalent to one lavatory.

Restaurant. For the purpose of this table, a restaurant is defined as a business that sells food to be consumed on premises. The number of occupants for a drive-in restaurant shall be considered as equal to the number of parking stalls. A hand sink is required to be available to employees in a restaurant or other food preparation occupancy.

Subsection 414.5 does not apply.

5. **Water heaters.** Does not apply.
6. **Water supply and distribution.** Add to 602.4. Every building intended for human habitation, occupancy, or use, and located on premises where public water is available, must be connected to such public water. Public water is considered available if located within two hundred feet [60.96 meters] from any proposed building required to have potable water located on any lot or premises which abuts and is served by public water.

Delete from 604.2 exception: or underground outside of structures.

Delete from 604.8 exception: Plastic materials for water service piping outside underground shall have a blue insulated copper tracer wire or other approved conductor installed adjacent to the piping. Access shall be provided to the tracer wire or the tracer wire shall terminate aboveground at each end of the nonmetallic piping. The tracer wire size shall be not less than eighteen AWG and the insulation type shall be suitable for direct burial.

Add to 604.10: new heading "Lead Content"; also add additional sentence to the end of the paragraph: Effective January 4, 2014, the maximum allowable lead content shall not exceed a weighted average of zero point two five (0.25) percent with respect to wetted surfaces of pipes, pipe fittings, plumbing fittings, and fixtures used to convey or dispense water for human consumption.

Add to 605.2: Each building water supply shall be provided with a fullway valve installed on the inlet side of each water meter. Valves up to and including two inches [50.8 millimeters] in size must be a ball valve.

Add to 605.3: Wall hydrants must be separately controlled by an accessible valve inside the building.

7. **Sanitary drainage.** Add to 705.1.6. For aboveground installations an approved shielded coupling must be used to prevent outward expansion.

Delete from 712.1: Except that plastic pipe shall not be tested with air. Add to table 7-1, under reference standards column for PVC, SDR 35 ASTM 3034 or heavier. Note 1.

Delete from 723.0: Plastic drainage waste and vent (DWV) piping systems shall not be tested by the air test method.

8. **Indirect wastes.** Add to 807.4 or the discharge line from the dishwasher may be looped up and securely fastened to the underside of the counter.
9. **Vents.** Subsections 908.2.1, 908.2.2, and 908.2.3 do not apply: Replace 908.2.1 with an individually vented lavatory in a single bathroom or single toilet room shall be permitted to serve as the wet vent for one water closet and one bathtub or shower stall, or one water closet and one bathtub and shower combination if all of the following conditions are met:
 - a. The wet vent, and the dry vent extending from the wet vent, shall be two inches [50.8 millimeters] minimum pipe size.
 - b. The wet vent pipe opening shall not be below the weir of the trap that it serves. Vent sizing, grades, and connections shall comply with sections 904.0 and 905.0.
 - c. The horizontal branch drain serving both the lavatory and the bathtub or shower stall shall be two inches [50.8 millimeters] minimum pipe size.
 - d. The length of the trap arm from the bathtub or shower stall complies with the limits in table 10-1.
 - e. The distance from the outlet of the water closet to the connection of the wet vent complies with the limits in table 10-1.
 - f. The horizontal branch drain serving the lavatory and the bathtub or shower stall shall connect to the horizontal water closet branch above its centerline. When the bathroom or toilet room is the topmost load on a stack, the horizontal branch serving the lavatory and the bathtub or shower stall shall be permitted to connect to the stack below the water closet branch.
 - g. No fixture other than those listed in L 6.2.1 shall discharge through a single bathroom or single toilet room wet-vented system.

Replace 908.2.2 with: Double Bathtubs, Bathtub and Shower Combinations, Shower Stalls, and Lavatories.

Two lavatories, each rated at 1.0 drainage fixture unit, and two bathtubs,

bathtub and shower combinations or shower stalls, installed in adjacent bathrooms, shall be permitted to drain to a horizontal drain branch that is two inches [50.8 millimeters] minimum pipe size, with a common vent for the lavatories and no individual vents for the bathtubs, bathtub and shower combinations or shower stalls, provided that the wet vent from the lavatories and their dry vent is two inches [50.8 millimeters] minimum pipe size and the length of all trap arms comply with the limits in table 10-1.

Add to 909.0. A combination waste and vent system may also be used for island sinks. The vertical waste pipe must be the same size as required for the combination waste and vent. The fixture trap size must be as required by chapter 7.

Subsection 910.2 does not apply.

10. **Traps and interceptors.** No change.
11. **Storm drainage.** No change.
12. **Fuel piping.** Does not apply.
13. **Health care facilities and medical gas and vacuum systems.** Does not apply.
14. **Referenced standards.** No change.
15. **Firestop protection.** Does not apply.
16. **Nonpotable water reuse systems.** No change.
17. **Appendix E, manufactured or mobile home parks and recreational vehicle parks.** Add to E1.0 water and sewer connections under the manufactured home may be made by individuals certified by the North Dakota department of commerce in accordance with the North Dakota manufactured home installation guidelines.

Part D does not apply.

18. **Appendix L.** Delete from L8.1 circuit venting shall be designed by a registered professional engineer as an engineered design.

History: Effective March 1, 2000; amended effective March 1, 2002; April 1, 2010; January 4, 2014.

General Authority: NDCC 43-18-09

Law Implemented: NDCC 43-18-09

**TABLE 2902.1
MINIMUM NUMBER OF REQUIRED PLUMBING FIXTURES***

CLASSIFICATION AND OCCUPANCY	DESCRIPTION	WATER CLOSETS (g)		LAVATORIES (h)		BATHTUBS AND SHOWERS	DRINKING FOUNTAINS (e,f)	OTHER	
		MALE	FEMALE	MALE	FEMALE				
A S S E M B L Y	A-1 (d)	Theaters and other buildings for the performing arts and motion pictures	1 per 125	1 per 65	1 per 200		-	1 per 500	1 service sink
	A-2 (d)	Nightclubs, bars, taverns, dance halls and buildings for similar purposes	1 per 40	1 per 40	1 per 75		-	1 per 500	1 service sink
		Restaurants, (i) banquet halls and food courts	1 per 75	1 per 75	1 per 200		-	1 per 500	1 service sink
	A-3 (d)	Auditoriums without permanent seating, art galleries, exhibition halls museums, lecture halls, libraries, arcades and gymnasiums	1 per 125	1 per 65	1 per 200		-	1 per 500	1 service sink
		Passenger terminals and transportation facilities	1 per 500	1 per 500	1 per 750		-	1 per 1,000	1 service sink
		Places of worship and other religious services	1 per 150	1 per 75	1 per 200		-	1 per 1,000	1 service sink
	A-4	Coliseums, arenas, skating rinks, pools and tennis courts for indoor sporting events and activities	1 per 75 for the first 1,500 and 1 per 120 for the remainder exceeding 1,500	1 per 40 for the first 1,520 and 1 per 60 for the remainder exceeding 1,520	1 per 200	1 per 150	-	1 per 1,000	1 service sink
	A-5	Stadiums, amusement parks, bleachers and grandstands for outdoor sporting events and activities	1 per 75 for the first 1,500 and 1 per 120 for the remainder exceeding 1,1500	1 per 40 for the first 1,520 and 1 per 60 for the remainder exceeding 1,520	1 per 200	1 per 150		1 per 1,000	1 service sink

(Table 2902.1 continued)

CLASSIFICATION AND OCCUPANCY	DESCRIPTION	WATER CLOSETS (g)		LAVATORIES (h)		BATHTUBS AND SHOWERS	DRINKING FOUNTAINS (e,f)	OTHER	
		MALE	FEMALE	MALE	FEMALE				
B U S I N E S S	B	Buildings for the transaction of business, professional services, other services involving merchandise, office buildings, banks, light industrial and similar uses	1 per 25 for the first 50 and 1 per 50 for the remainder exceeding 50		1 per 40 for the first 80 and 1 per 80 for the remainder exceeding 80		-	1 per 100	1 service sink
E D U C A T I O N A L	E	Educational facilities	1 per 50		1 per 50		-	1 per 100	1 service sink
I N D U S T R I A L	F-1 and F-2	Structures in which occupants are engaged in work fabricating, assembly or processing of products or materials	1 per 100		1 per 100			1 per 400	1 service sink
I N S T I T U T I O N A L	I-1	Residential care	1 per 10		1 per 10		1 per 8	1 per 100	1 service sink
	I-2	Hospitals, ambulatory nursing home patients (b)	1 per per room (c)		1 per per room (c)		1 per 15	1 per 100	1 service sink
		Employees, other than residential care (b)	1 per 25		1 per 35		-	1 per 100	-
		Visitors, other than residential care	1 per 75		1 per 100		-	1 per 500	-
	I-3	Prisons (b)	1 per cell		1 per cell		1 per 15	1 per 100	1 service sink
	I-3	Reformatories, detention centers and correctional centers (b)	1 per 15		1 per 15		1 per 15	1 per 100	1 service sink
		Employees (b)	1 per 25		1 per 35		-	1 per 100	-
	I-4	Adult day care and child care	1 per 15		1 per 15		1	1 per 100	1 service sink

(Table 2902.1 continued)

CLASSIFICATION AND OCCUPANCY	DESCRIPTION	WATER CLOSETS (g)		LAVATORIES (h)		BATHTUBS AND SHOWERS	DRINKING FOUNTAINS (e,f)	OTHER	
		MALE	FEMALE	MALE	FEMALE				
M E R C A N T I L E	M	Retail stores, service stations, shops, sales- rooms, markets and shopping centers	1 per 500		1 per 750		-	1 per 1,000	1 service sink
R E S I D E N T I A L	R-1	Hotels, motels, boarding houses (transient)	1 per sleeping unit		1 per sleeping unit		1 per sleeping unit	-	1 service sink
	R-2	Dormitories, fraternities, sororities and boarding houses (not transient)	1 per 10		1 per 10		1 per 8	1 per 100	1 service sink
	R-2	Apartment house	1 per dwelling unit		1 per dwelling unit		1 per dwelling unit	-	1 kitchen sink per dwelling unit; 1 automatic clothes washer connection per 20 dwelling units
	R-3	Congregate living facilities with 16 or fewer person	1 per 10		1 per 10		1 per 8	1 per 100	1 service sink
	R-4	Residential care/assisted living facilities	1 per 10		1 per 10		1 per 8	1 per 100	1 service sink
S T O R A G E	S-1 S-2	Structures for the storage of goods, warehouses, storehouses and freight depots, low and moderate hazard	1 per 100		1 per 100			1 per 1,000	1 service sink

TABLE 2902.1: NOTES

- a. The fixtures shown are based on one fixture being the minimum required for the number of person indicated or any fraction of the number of persons indicated. The number of occupants shall be determined by Table 1004.1.1 of the International Building Code. Types of occupancies not shown on this table shall be considered individually by the administrative authority. The occupancy load shall be composed of fifty percent of each sex.
- b. Toilet facilities for employees shall be separate from facilities for inmates or patients.
- c. A single-occupant toilet room with one water closet and one lavatory serving not more than two adjacent patient sleeping units shall be permitted where such room is provided with direct access from each patient sleeping unit and with provisions for privacy.
- d. The occupant load for seasonal outdoor seating and entertainment areas shall be included when determining the minimum number of facilities required.
- e. The minimum number of required drinking fountains shall comply with Table 2902.1.
- f. Drinking fountains are not required for an occupant load of 30 or fewer. There shall be a minimum of one drinking fountain per occupied floor in schools, theaters, auditoriums, dormitories, and businesses.
 - Where food is consumed indoors, water stations may be substituted for drinking fountains.
 - Where bottled water coolers are provided, drinking fountains shall not be required.
 - Drinking fountains shall not be installed in toilet rooms
- g. The provision of urinals may offset water closets otherwise required but the number of water closets required may not be reduced in this manner by more than fifty percent.
 - Walls and floors within two feet [609.6 millimeters] of the sides and front of urinals must be finished with a smooth, hard, nonabsorbent finish.
- h. Where circular or similar handwashing applications are provided, twenty-four lineal inches [609.6 millimeters] of wash sink or eighteen inches [457.2 millimeteres] of a circular basin, when provided with water outlets for such space, shall be considered equivalent to one lavatory.
- i. For the purpose of this table, a restaurant is defined as a business that sells food to be consumed on premises. The number of occupants for a drive-in restaurant shall be considered as equal to the number of parking stalls.
 - A hand sink is required to be available to employees in a restaurant or other food preparation occupancy.

**TABLE 1004.1.1
MAXIMUM FLOOR AREA ALLOWANCES
PER OCCUPANT**

OCCUPANCY	FLOOR AREA IN SQ. FT. PER OCCUPANT
Accessory storage areas, mechanical equipment room	300 gross
Agricultural building	300 gross
Aircraft hangars	500 gross
Aircraft terminal	
Baggage claim	20 gross
Baggage handling	300 gross
Concourse	100 gross
Waiting areas	15 gross
Assembly	
Gaming floors (keno, slots, etc)	11 gross
Assembly with fixed seats	Number of seats
Assembly without fixed seats	
Concentrated (chairs only – not fixed)	7 net
Standing space	5 net
Unconcentrated (tables and chairs)	15 net
Bowling centers, allow 5 persons for each lane including 15 feet of runway, and for additional areas	7 net
Business areas	100 gross
Courtrooms-other than fixed seating areas	40 net
Day care	35 net
Dormitories	50 gross
Educational	
Classroom area	20 net
Shops and other vocational room areas	50 net
Exercise rooms	50 gross
H-5 Fabrication and manufacturing areas	200 gross
Industrial areas	100 gross
Institutional areas	
Inpatient treatment areas	240 gross
Outpatient areas	100 gross
Sleeping areas	120 gross
Kitchens, commercial	200 gross
Library	
Reading rooms	50 net
Stack area	100 gross
Locker rooms	50 gross
Mercantile	
Areas on other floors	60 gross
Basement and grade floor areas	30 gross
Storage, stock, shipping areas	300 gross
Parking garages	200 gross
Residential	200 gross
Skating rinks, swimming pools	50 gross
Rink and pool Decks	15 gross
Stages and platforms	15 net
Warehouses	500 gross

**CHAPTER 62-03.1-03
PRIVATE SEWAGE DISPOSAL SYSTEMS**

Section

62-03.1-03-01	General Provisions
62-03.1-03-02	Installation—Excavator and Installer Requirements
62-03.1-03-03	Design of Individual Sewage System
62-03.1-03-04	Location of Sewage System
62-03.1-03-05	Percolation Tests
62-03.1-03-06	Soil Borings
62-03.1-03-07	Septic Tanks
62-03.1-03-08	Distribution Box
62-03.1-03-09	Absorption Trenches
62-03.1-03-10	Piping Material
62-03.1-03-11	Pumps and Pumps Systems
62-03.1-03-12	Alternative Systems
62-03.1-03-13	Chemical Toilets
62-03.1-03-14	Privies
62-03.1-03-15	Septic Tank Pumpers

62-03.1-03-01. General provisions.

1. All sewage treatment systems shall be constructed, added to, or altered in accordance with this chapter. When a public or noncommunity sewerage system is deemed available to a premise used for human occupancy if such premise is within two hundred feet [60.96 meters], the approving authority shall require that sewage be discharged into that system.
2. Where public or noncommunity sewage treatment systems are not available and construction of an individual sewage treatment system is contemplated for a building of human occupancy or use or addition to, or alteration of any existing sewage treatment system, the master plumber or sewer and water contractor, or septic system installer, previous to beginning any construction may be required to make application to the local or district health units for a written permit to make the desired installation.
3. "Sewage treatment" under this section means all private methods of collecting and disposing of domestic sewage including septic tanks, privies, chemical toilets, and any others.
4. All domestic sewage shall be disposed of by an approved method of collection, treatment, and effluent discharge. Domestic sewage or sewage effluent shall not be disposed of in any manner that will cause pollution of the ground surface, ground water, bathing area, lake, pond, watercourse, or create a nuisance. It shall not be discharged into any abandoned or unused well, or into any crevice, sinkhole, or other opening either natural or artificial in a rock formation.

5. Where water under pressure is not available, all human body wastes shall be disposed of by depositing them in approved privies, chemical toilets, or such other installations acceptable to the administrative authority.
6. Water-carried sewage from bathrooms, kitchens, laundry fixtures, and other household plumbing shall pass through a septic or other approved sedimentation tank prior to its discharge into the soil or into an alternative system. Where underground disposal for treatment is not feasible, consideration will be given to special methods of collection and disposal.
7. The building contractor, owner, plumbing contractor, or disposal system installer are jointly responsible for compliance with this chapter.
8. Abandoned disposal systems, septic tanks, pumping and other chambers, and seepage beds shall be disconnected from the buildings. The tanks and chambers shall be pumped out and filled with earth.
9. No property shall be improved in excess of its capacity to properly absorb sewage effluent in the quantities and by the means provided in this code.
10. When there is insufficient lot area or improper soil conditions for adequate sewage treatment for the building or land use proposed, and the administrative authority so finds, no building permit shall be issued and no private sewage treatment shall be permitted. Where space or soil conditions are critical, no building permit shall be issued until engineering data and test reports satisfactory to the administrative authority have been submitted and approved or a private sewage treatment system complying with the provisions of this article has first been designed.
11. Nothing contained in this chapter shall be construed to prevent the administrative authority from requiring compliance with higher requirements than those contained herein where such higher requirements are essential to maintain a safe and sanitary condition.
12. "Administrative authority" under this section means the North Dakota state plumbing board, North Dakota state department of health, district health units, county or city health departments which have expertise in onsite sewage treatment systems, or individual official, board, department, or agency established and authorized by a state, county, city, or other political subdivision created by law to administer and enforce the provisions of this chapter.
13. "Continuing education" under this section means a structured, professional presented curriculum dealing with onsite sewage treatment systems sanctioned wholly or in part by the administrative authority.
14. "Installer" under this section means an individual or contractor that engages in the construction of onsite sewage treatment systems. Homeowners who work on their own systems are not included in this definition.

15. "Mottled soil" under this section means soil from a soil boring which is marked with spots of contrasting colors. Any soil having spots of contrasting colors is considered mottled.
16. "Sewage treatment" under this section means all private methods of collecting and disposing of domestic sewage including septic tanks, privies, chemical toilets, and any others.
17. A "chamber or pump chamber" under this section means a watertight receptacle for receiving effluent from the septic tank which will be used for placement of an effluent grade pump to distribute that effluent to the treatment area.
18. "Noncommunity" under this section means a collector system for sewage disposal serving a group of homes, which uses lagoons or other collective methods of disposal and treatment, which are not otherwise regulated by the environmental protection agency or state regulations.

62-03.1-03-02. Installation – Excavator and installer requirements.

1. Individuals or business contractors may be required by the administrative authority to have or obtain a license or permit to install individual onsite sewage treatment systems as described in this chapter.
2. Where required by administrative authority, installers of septic systems must obtain at least eight contact hours of suitable continuing education every two years, which pertains to onsite septic system installation. Reciprocity for training in other states can be made on an individual basis by the administrative authority.
3. The installer of a treatment system shall submit an "as built" drawing of the system to the administrative authority within thirty days after the system has been completed.

62-03.1-03-03. Design of individual sewage system.

1. **Design.** The design of the individual sewage treatment system must take into consideration location with respect to wells or other sources of water supply, topography, water table, soil characteristics, area available, and maximum occupancy of the building.
2. **Type of system.** The type of system to be installed shall be determined on the basis of location, soil permeability, and ground water elevation.
3. **Sanitary sewage.** The system shall be designed to receive all sanitary sewage, including laundry waste, from the building. Drainage from footings or roofs shall not enter the system.

4. **Discharge.** The system shall consist of a septic tank discharging into either a subsurface treatment field or one or more seepage beds or into a combination of both, if found adequate as such and approved by the administrative authority.
5. **Ground water.** No plumbing fixture may be connected to any individual sewage treatment system where ground water may collect above the sewage treatment system causing a flooded condition, unless the elevation of the fixture trap is a sufficient height above the elevation of the finished grade of the ground in which the sewage treatment field is installed to prevent backup. The minimum separation distance from the bottom of the treatment area must equal or exceed twenty-four inches [60.96 centimeters].
6. **Alternate design.** Where soil conditions are such that neither of the systems mentioned in subsection 4 can be expected to operate satisfactorily, approval of an alternate design shall be secured from the administrative authority.
7. **Sewage flow.** Design criteria for sewage flow according to the type of establishment is indicated in the following table:

SEWAGE FLOWS ACCORDING TO TYPE OF ESTABLISHMENT

TYPE OF ESTABLISHMENT	GALLONS PER PERSON PER DAY (UNLESS OTHERWISE NOTED)
Airports (per passenger)	5
Apartment-multiple family (per resident)	60
Assembly halls (per seat)	2
Bars (per seat)	5
Bathhouses and swimming pools	10
Bowling alleys (per lane)	75
Camps:	
Campground with central comfort stations	35
With flush toilets, no showers	25
Construction camps (semipermanent)	50
Day camps (no meals served)	15
Resort camps (night and day) with limited plumbing	50
Luxury camps	100
Churches (per sanctuary seat)	5
Churches with kitchens (per sanctuary seat)	7
Cottages and small dwellings with seasonal occupancy	50
Country clubs (per member present)	25
Dwellings:	
Boardinghouses	50

Additional for nonresident boarders	10
Luxury residences and estates	150
Multiple family dwellings (apartments)	60
Roominghouses	40
Single-family dwellings	75
Factories (gallons per person, per shift, exclusive of industrial wastes)	35
Hospitals (per bed space)	250
Hotels (per guest)	50
Institutions other than hospitals (per bed space)	100
Laundries, self-service (gallons per machine)	500
Mobile home parks (per space)	250
Motels (per bed space)	50
Picnic parks (sanitary waste only)	5
Picnic parks with bathhouse, showers, and flush toilets	10
Restaurants (toilet and kitchen wastes per patron)	10
Restaurants (kitchen wastes per meal served)	3
Restaurants additional for bars and cocktail lounges	2
Schools:	
Boarding	75
Day, without gyms, cafeterias, or showers	15
Day, with gyms, cafeteria, and showers	25
Day with cafeteria, but without gyms or showers	20
Service stations (per vehicle served)	10
Theaters:	
Movie (per auditorium seat)	5
Drive-in (per car space)	5
Travel trailer parks without individual water and sewer hookups (per space)	50
Travel trailer parks with individual water and sewer hookups (per space)	100
Workers:	
Construction (at semipermanent camps)	50
Day, at school and offices (per shift)	15

62-03.1-03-04. Location of sewage system.

1. The minimum lot size in which a private treatment system may be installed is forty thousand square feet [3716.00 square meters]. Smaller lot sizes may be approved by the administrative authority if a centralized sewage treatment system is provided or the soil conditions present throughout the lot are such that a second treatment area is able to be installed in the lot.

2. The following table provides for the minimum distances that shall be observed in locating the various components of the treatment system:

	Well 100'	Well 100'	Distribution Device	Treatment Area	Property Lines	Building
Building Sewer	100	50	-	-	-	-
Septic Tank	100	50	5	10	10	10
Distribution Device	100	50	-	-	10	20
Treatment Area	100	50	5	-	10	10
Well 100'	-	-	100	100	n/a	n/a
Well 100'	-	-	50	50	n/a	n/a
Water line (pressure) (suction)	-	-	10 50	10 50	n/a n/a	n/a n/a
Water line	-	-	50	50	n/a	n/a
Surface Water bodies	n/a	n/a	100	100	n/a	n/a

3. All proposed sites for individual sewage treatment systems must be evaluated as to:
- Depth to the highest known or calculated ground water table or bedrock;
 - Soil conditions, properties, and permeability;
 - Slope;
 - The existence of lowlands, local surface depressions, and rock out-crops;
 - All legal setback requirements from existing and proposed buildings, property lines, sewage tanks, soil treatment systems, water supply wells, buried water pipes and utility lines, the ordinary high water mark of lakes, rivers, streams, flowages, and the location of all soil treatment systems and water supply wells on adjoining lots to the proposed soil treatment system, sewage tank, and water supply well; and
 - Surface water flooding probability.
4. Privies, septic tanks, and underground treatment means shall not be within two hundred feet [60.96 meters] measured horizontally from the high water level in the reservoir or the banks of tributary streams when situated less than three thousand feet [914.4 meters] upstream from potable water intake structures. Sewage treatment facilities situated beyond three thousand feet [914.4 meters] upstream from intake structures shall be located no less than one hundred feet [30.48 meters] measured horizontally from the high water level in the reservoir or the banks of the tributary streams.

62-03.1-03-05. Percolation tests. When percolation tests are required, they must be made as follows:

1. **Test hole dimensions and locations.** Each test hole must be six inches [15.24 centimeters] in diameter, have vertical sides, and be bored or dug to the depth of the bottom of the proposed individual sewage treatment system. Soil texture descriptions must be recorded noting depths where texture changes occur.
2. **Preparation of the test hole.** The bottom and sides of the hole must be carefully scratched to remove any smearing and to provide a natural soil surface into which water may penetrate.

All loose material must be removed from the bottom of the test hole and two inches [5.08 centimeters] of one-fourth-inch to three-fourths-inch [.635-centimeter to 1.90-centimeter] gravel must be added to protect the bottom from scouring.

3. **Soil saturation and swelling.** The hole must be carefully filled with clear water to a minimum depth of twelve inches [30.48 centimeters] over the soil at the bottom of the test hole and maintained for no less than four hours. The soil must then be allowed to swell for at least sixteen, but no more than thirty hours. In sandy soils, the saturation and swelling procedure is not required and the test may proceed if one filling of the hole has seeped away in less than ten minutes.
4. **Percolation rate measurement.**
 - a. In sandy soils. Adjust the water depth to eight inches [20.32 centimeters] over the soil at the bottom of the test hole. From a fixed reference point, the drop in water level must be measured in inches [centimeters] to the nearest one-eighth inch [.34 centimeter] at approximately ten-minute intervals. A measurement can also be made by determining the time it takes for the water level to drop one inch [2.54 centimeters] from an eight-inch [20.32 centimeters] reference point. If eight inches [20.32 centimeters] of water seeps away in less than ten minutes, a shorter interval between measurements must be used, but in no case may the water depth exceed eight inches [20.32 centimeters]. The test must continue until three consecutive percolation rate measurements vary by a range of no more than ten percent.
 - b. In other soils. Adjust the water depth to eight inches [20.32 centimeter] over the soil at the bottom of the test hole. From a fixed reference point, the drop in water level must be measured in inches [centimeters] to the nearest one-eighth inch [.34 centimeter] at approximately thirty-minute intervals, refilling between measurements to maintain an eight-inch [20.32 centimeter] starting head.

The test must continue until three consecutive percolation rate measurements vary by a range of no more than ten percent. The percolation rate can also be made by observing the time it takes the water level to drop one inch [2.54 centimeters] from an eight-inch [20.32 centimeters] reference point if a constant water depth of at least eight inches [20.32 centimeters] has been maintained for at least four hours prior to the measurement.

5. **Calculating the percolation rate.** Divide the time interval by the drop in water level to obtain the percolation rate in minutes per inch [2.54 centimeters].

Percolation rates determined for each test hole must be averaged to determine the final soil treatment system design.

A percolation test may not be run where frost exists below the depth of the proposed soil treatment system.

62-03.1-03-06. Soil borings. When soil borings are required, they must be made as follows:

1. Each boring or excavation must be made to a depth at least three feet [0.91meters] deeper than the bottom of the proposed system or until bedrock or a water table is encountered, whichever is less.
2. A soil texture description must be recorded by depth and notations made where texture changes occur.
3. Particular effort must be made to determine the highest known water table by recording the first occurrence of mottling observed in the hole, or if mottling is not encountered, the open holes in clay or loam soils must be observed after standing undisturbed a minimum of sixteen hours, and depth to standing water, if present, must be measured.

62-03.1-03-07. Septic tanks.

1. **Liquid capacity.** The liquid capacity of all septic tanks shall conform to the tables contained in subsection 7 of section 62-03.1-03-03 and this subsection as determined by the number of bedrooms or apartment units in dwelling occupancies and the occupant load or the number of plumbing fixture units as determined from table 7-3 of the Uniform Plumbing Code, whichever is greater, in other building occupancies.

CAPACITY OF SEPTIC TANKS*

Single-Family Dwellings – Number of Bedrooms	Multiple Dwelling Units or Apartments – One Bedroom Each	Other Uses – Maximum Fixture Units Served	Minimum Septic Tank Working Capacity in Gallons
1-3		20	1000
4	2	25	1200
5 or 6	3	33	1500
7 or 8	4	45	2000
	5	55	2250
	6	60	2500
	7	70	2750
	8	80	3000
	9	90	3250
	10	100	3500

Extra bedroom, 150 gallons each.

Extra dwelling units over 10, 250 gallons each.

Extra fixture units over 100, 25 gallons per fixture unit.

***Note:** Septic tank sizes in this table include sludge storage capacity and the connection of domestic food waste disposal units without further volume increase.

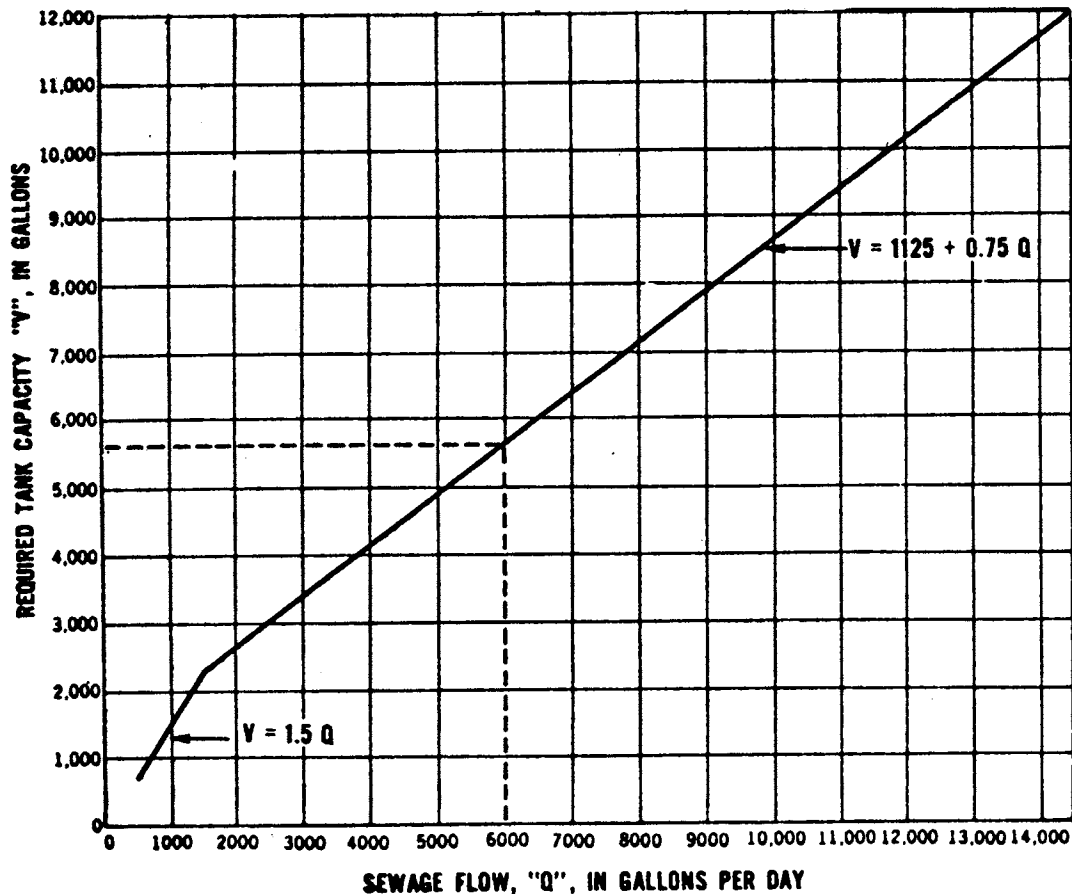

2. **Septic tank construction.** Septic tanks must be constructed of sound durable materials not subject to excessive corrosion or decay and must be watertight. Each such tank must be structurally designed to withstand all anticipated earth or other loads and must be installed level and on a solid bed. All tanks regardless of material or method of construction must conform to the following criteria:
- a. The liquid depth of any septic tank or compartment shall be not less than thirty inches [76.20 centimeters], nor more than six and one-half feet [1.97 meters]. No tank may have an inside horizontal dimension less than twenty-four inches [60.96 centimeters].
 - b. The space in the tank between the liquid surface and the top of the inlet and outlet baffles must be not less than twenty percent of the total required liquid capacity, except that in horizontal cylindrical tanks this space must be not less than fifteen percent of the total required liquid capacity.
 - c. There must be at least one inch [2.54 centimeters] between the underside of the top of the tank and the highest point of the inlet and outlet devices. The inlet invert must be not less than three inches [7.62 centimeters] above the outlet invert.
 - d. Baffles must be integrally cast with the tank, affixed with a permanent waterproof adhesive or affixed with stainless steel connectors, top and bottom, and be constructed of anti-resistant concrete, acid-resistant fiberglass or plastic.
 - e. The inlet baffle must extend at least six inches [15.24 centimeters], but not more than twenty percent of the total liquid depth below, the liquid surface and at least one inch [2.54 centimeters] above the crown of the inlet sewer.
 - f. The outlet baffle and the baffles between compartments must extend below the liquid surface a distance equal to forty percent of the liquid depth, except that the penetration of the indicated baffles or sanitary tees for horizontal cylindrical tanks must be thirty-five percent of the total liquid depth. They also must extend above the liquid surface. In no case may they extend less than six inches [15.24 centimeters] above the liquid surface.
 - g. Inlet baffles must be no less than six inches [15.24 centimeters] or no more than twelve inches [30.48 centimeters] measured from the end of the inlet pipe to the nearest point on the baffle. Outlet baffles must be six inches [15.24 centimeters] measured from beginning of the outlet pipe to the nearest point on the baffle. Sanitary tees used as baffles must be at least four inches [10.16 centimeters] in diameter.

- h. The inlet and outlet must be located opposite each other along the axis of maximum dimension. The horizontal distance between the nearest points of the inlet and outlet devices must be at least four feet [1.22 meters].
- i. There may be one or more manholes. Manholes must be at least eighteen inches [45.72 centimeters] in diameter, and located within six feet [1.83 meters] of all walls of the tank. The manhole must extend through the cover to a point within twelve inches [30.48 centimeters] but no closer than six inches [15.24 centimeters] below finished grade. The manhole cover must be corrosion resistant, rated three- hundred pound [136.07- kilogram] load bearing, and covered with at least six inches [15.24 centimeters] of earth. When in the opinion of the administrative authority the manhole is permitted above finish grade, it must be safely secured.
- j. There must be an inspection pipe of at least four inches [10.16 centimeters] in diameter or a manhole over both the inlet and outlet devices. The inspection pipe must extend through the cover and be capped flush or above finished grade. A downward projection of the centerline of the inspection pipe must be directly in line with the centerline of the inlet or outlet device.

3. Multiple tanks.

- a. When more than one tank is used to obtain the required liquid volume, the tanks must be connected in series.
- b. No more than four tanks in series can be used to obtain the required liquid volume.
- c. The first tank must be no smaller than any subsequent tanks in series.

4. Septic tank materials. See table 14-1 of the Uniform Plumbing Code.

5. Depth of septic tank. Where septic tanks are installed above frostline, precautions must be taken to prevent the septic tank from freezing.

6. Service limited. No septic tank shall serve more than one property unless authorized by the administrative authority.

7. Disposal of effluent. The effluent from all septic tanks shall be disposed of underground by subsurface absorption trench, seepage beds, or approved alternative systems.

62-03.1-03-08. Distribution box

- 1. **Use.** A distribution box may be used when more than one line of absorption field or more than one seepage bed is used.

2. **Connection.** Each lateral line shall be connected separately to the distribution box and shall not be subdivided.
3. **Invert level.** The inlet invert shall be at least one inch [2.54 centimeters] above the invert of the outlets. The size of the distribution box shall be sufficient to accommodate the number of lateral lines.
4. **Watertight.** The distribution box shall be of watertight construction arranged to receive the septic tank effluent sewer and with an outlet or connecting line serving each trench or seepage bed.
5. **Inspection.** The sides of the box should extend to within a short distance of the ground surface to permit inspection and shall have a concrete marker at grade.

62-03.1-03-09. Absorption trenches.

1. **Design.** Adsorption trenches shall be designed and constructed on the basis of the percolation test results or other soil data. Trench bottom area required is shown in the table in subsection 4. The bottom of the trench shall be dug so it is dead level throughout its length. The maximum depth to the bottom of absorption trenches may not exceed forty-eight inches [121.92 centimeters]. The trench bottom must be at least twenty-four inches [60.96 centimeters] above the mottled soil condition indicating a water table or from standing water in the borehole.
2. **Filter material.** The filter material shall cover the four-inch [10.16 centimeter] diameter pipe to a depth of two inches [3.08 centimeters] measured from the crown of the pipe and extend the full width of the trench and shall be not less than six inches [15.24 centimeters] deep beneath the bottom of the four inch [10.16 centimeter] diameter pipe. The filter material may be washed rock or crushed stone ranging in size from one inch to three inches [2.54 centimeters to 7.62 centimeters]. The filter material shall be covered by red rosin paper, hay, straw, or approved filter fabric, as the laying of the pipe proceeds. Approve graveless systems may be used in lieu of rockfill providing an equivalent surface area of soil is utilized.
3. **Spacing.** Trenches must have a minimum spacing of undisturbed earth of six feet [1.83 meters] for eighteen-inch to twenty-four-inch [45.72-centimeter] to 60.96-centimeter] trench widths and nine feet [2.74 meters] for trenches up to thirty-six inches [91.44 centimeters] wide.
4. **Adsorption field.** The size and requirements for absorption fields shall conform to those given in the following table:

Table – Recommended absorption trench area.

Percolation Rate Minutes/Inch	Soil Classification	Depth of Rock Below Distribution Pipe			
		6"	12"	18"	24"
-Trench bottom area loading rate, gal/ft.²/day					
.1 to 5	Sand	1.2	1.5	1.80	2.1
6 to 15	Sandy loam	0.8	1.0	1.20	1.4
16 to 30	Loam	0.6	0.75	0.90	1.05
31 to 45	Silt loam	0.5	0.63	0.76	0.89
46 to 60	Clay loam	0.45	0.57	0.68	0.79
-Square feet of trench bottom/bedroom¹					
.1 to 5		125	100	85	70
6 to 15		190	150	125	110
16 to 30		250	200	165	145
31 to 45		300	240	200	170
46 to 60		330	265	220	190

¹Based on sewage volume of 150/GPD Bedroom

5. Adsorption lines.

- a. Gravity distribution. Adsorption lines shall be constructed of four-inch [10.16-centimeter] pipe. For approved plumbing materials, see table 14-1 of chapter 14 of the Uniform Plumbing Code.
- b. Pressure distribution. Adsorption lines must be constructed of one and one-half-inch to two-inch [3.81 centimeter to 5.08 centimeter] rigid plastic pipe with one-fourth inch [6.35-millimeter] holes drilled in the bottom of the pipes. The number of perforations and spacing of perforations for different diameter pipes for pressure distribution laterals must not exceed ten percent of the average pressure head on the perforations. The pipe and connections must be able to withstand a pressure of at least forty pounds per square inch. The perforated laterals should be attached to a two-inch [5.08-centimeter] manifold pipe and should have the ends capped. The laterals should be spaced no further than forty inches [101.6 centimeters] on center and no further than twenty inches [50.80 centimeters] from the edge of the rock. Pipe must be installed level and capped at the ends. The manifold must be supported and backfilled by hand.

6. Grade. The absorption trench bottom must be level.

62-03.1-03-10. Piping material. All piping from building drain to sewage treatment system shall be four inches [10.16 centimeters] or larger service schedule 40 acrylonitrile-butadiene-styrene or polyvinyl chloride plastic pipe, type PSP PVC sewer pipe SDR 35, and fittings A.S.T.M. D3033 or D3034, exclusive of the absorption lines, which shall be as in subsection 5 of section 62-03.1-03-09.

62-03.1-03-11. Pumps and pump systems. This section pertains to pumps installed after the septic tank. Sumps and ejectors installed before the septic tank must meet the requirements set forth in section 710.0 of the Uniform Plumbing Code.

1. Pumping chambers.

- a. The pumping chambers must be watertight and constructed of corrosion-resistant material.
- b. The working capacity of the pumping chamber must equal one-fourth of the daily sewage flow. Total capacity of the pumping chamber must equal or exceed daily sewage flow.
- c. A secure cover must be provided that is either bolted on or heavy enough to prevent unauthorized entry.
- d. An external electrical outlet must be provided for connection to the pump and control switches. Openings for wiring into the pump chamber must be sealed.
- e. No electrical splices or connections shall be located in the pump chamber or riser.

2. Pumps.

- a. Effluent lift pumps must be of cast bronze, cast iron, or plastic construction and must be designed for handling septic tank effluent. Pedestal sump pumps with an open motor are not allowed.
- b. Set the pump on a pedestal on the bottom of the pump chamber to minimize grit and solids entering the impeller.
- c. The pump must have maximum lift capability at least five feet [1.52 meters] greater than the actual elevation, plus pipe friction loss. A pump to a sewage mound ("Wisconsin mound") shall deliver seven and five-tenths gallons [28.38 liters] per minute for each one hundred square feet [9.29 square meters] of rock area.
- d. Outlet piping must be one and one-fourth inches [31.75 millimeters] in diameter or greater. The pipe must be laid below frostline or uniformly graded to drain back to the pump chamber. Volume of drain back should not exceed ten percent of the working capacity of the pump chamber. If piping is set to drain back, any check valves on the pump should be removed and a one-fourth-inch [6.35-millimeter] drainhole drilled on the low point of the outlet pipe. Piping connection to the pump must be with a union or quick disconnect coupling near the top of the pump chamber.

3. Pump controls.

- a. On-off switching for sewage pumps must be sealed mercury float switches or of a type approved by the administrative authority.
- b. Electrical connections must not be made in the pump chamber or pump chamber riser.

62-03.1-03-12. Alternative systems.

1. **Mounds.** Mounds may be constructed on soils having a percolation rate faster than on hundred twenty minutes per inch [2.54 centimeters]. For soils slower than one hundred twenty minutes per inch [2.54 centimeters], either the system must be moved to more amenable soil or see subsection 2 on lagoons.
 - a. Location. Mounds may not be located on sites of greater than twelve percent slope. For moderately permeable soils, the administrative authority may approve construction on slopes over six percent. Mounds may not be built in areas where water may pond.
 - b. Design. The basal sand area of the mound must be sized on the basis of eighty- three hundredths gallons [3.12 liters] per square foot [0.09 square meters] per day. The basal sand may be twelve inches to twenty-four inches [30.48 centimeters] to 60.96 centimeters] deep and must extend at least five feet [1.52 meters] beyond the rock filter material in all directions. The rock layer may be twelve inches to twenty-four inches [30.48 centimeters to 60.96 centimeters] deep and may not exceed ten feet [3.05 meters] in width. Only pressure distribution may be used in the mound, so piping shall be one and one-half-inch to two-inch [38.10-millimeter to 50.80-millimeter] diameter rigid ABS or PVC. A one and one-fourth inch [31.75 millimeters] hole must be drilled every thirty-six inches [91.44 centimeters] and the ends of the lateral must be capped. A one-fourth inch [6.35 millimeters] hole shall be drilled in the top of the cap to serve as a siphon break. Laterals shall be spaced no further than forty inches [101.60 centimeters] on center and no further than twenty inches [50.80 centimeters] from the edge of the filter rock. Surface water must be diverted by a berm located uphill from the base of the mound.
 - c. Specifications. Sand must be uniformly graded, with no more than fifteen percent fines. Filter rock must be one inch to three inches [25.40 millimeters to 76.20 millimeters] in diameter, washed or screened to less than ten percent fines.

A jar test should be used to determine sand suitability. In a one-quart [.95 liters] jar, place two inches [50.8 millimeters] of the sand. Add water to three-fourths level, cap, shake, and set aside to settle. If a layer of silt is present on top, which is more than one-eighth inch [3.18 millimeters] thick, the sand is not suitable for mound construction.

d. Construction.

1. Scarify the area with backhoe teeth or a cultivator. Do not remove topsoil. Bring outlet pipe from pump up into the center of the mound area.
2. Lay sand on scarified area. Do not compact the soil with machinery tires. Level sand to desired depth.
3. Lay filter rocks down the center of the sand layer. Level.
4. Connect piping to manifold and lay pipe on rock. Cover pipe with rock and level by hand. Holes must be on bottom of the pipe.
5. Lay sand up to the top of the rock on all sides, sloping sand away at a three-to-one or four-to-one slope.
6. Cover rock with red rosin paper, hay or filter fabric.
7. Backfill entire mound to a three-to-one or four-to-one grade. Downhill side of mound on slopes must be backfilled at a four- to-one or longer grade. Cover mound with topsoil.
8. Seed grass over mound. Trees and shrubs may be planted on the toe and up the sides of the mound, but do not plant shrubs or trees on top. If vegetation is not established before winter, cover mound with hay or straw to prevent freezing.

2. **Lagoons - Total containment.** In areas where normal septic systems will not function, and where the administrative authority finds that nuisance will not be presented, a lagoon may be used for onsite sewage disposal.

- a. Design. Depth may not exceed five feet [1.52 meters], and side berms shall be graded to three-to-one for proper aeration. The site must be fenced, and the berms must be seeded. The berms must be at least one foot [0.30 meter] higher than the liquid level at design capacity. Inlet pipes must discharge onto a splash pad to minimize erosion. Outlet pipes may not be installed without the approval of the administrative authority.
- b. Maintenance. Weeds must be controlled in the lagoon and on the berms to maximize aeration.
- c. Prohibitions. Lagoons may not be constructed on sand, gravel, or light loamy soils. No lagoon may be discharged into receiving waters or onto the ground without the approval of the state department of health.

3. **Alternative design.** Alternate designs for construction of sewage treatment systems complying with the intent of this code may be submitted to the administrative authority for approval.

62-03.1-03-13. Chemical toilets.

1. All requests for permission to erect and use chemical toilets shall be approved by the administrative authority.
2. Where approved by the administrative authority, chemical toilets shall be as follows:

A chemical toilet consists of a toilet seat connected by a metal hopper to a metal tank containing chemicals, usually sodium hydroxide. All connections to the toilet seat and the tank shall be watertight. A rod shall extend above the floor of the room to operate the agitator in the chemical tank.

3. A supply of the chemical shall be available in a closed container for periodic additions to the toilet.

62-03.1-03-14. Privies.

1. All requests for permission to erect and use privies shall be approved by the administrative authority.
2. General specifications for the design and construction of a privy. A privy pit must be constructed by providing a watertight structure in the pit. The watertight structure shall provide a minimum capacity of sixty cubic feet [1.70 cubic meters]. A privy building shall be placed over the structure. The floor of this building shall be of wood or concrete with the privy seat of suitable material, which is easily cleaned and serviceable. A vent located adjacent to the seat shall extend from the vault to a point above the roof of the building. The seat shall be provided with a cover, which shall be self-closing.

All openings in the building shall be screened to prevent the entrance of flies. The building shall be so constructed to prevent the entrance of rats to the vault. The privy door shall be self-closing.

3. Removable cans. When removable cans are used in a privy, they shall be placed in watertight vaults and provision made for removing the seat so the cans can be moved for disposal of the contents in a manner acceptable to the administrative authority. The privy building shall comply with the above specifications for a pit privy building.

62-03.1-03-15. Septic tank pumpers.

1. Every person engaged in the business of removing and disposing of the solid and liquid contents of private sewage treatment systems shall obtain an annual license from the state department of health.

2. All solid and liquid contents of chemical toilets, septic tanks, pump chambers, and watertight pits for septic tank effluent shall be removed, when necessary, and disposed of in conformance with subsections 3 through 9.
3. Every pumper shall obtain a license to engage in such operations as specified in the appropriate rules of the state department of health, chapter 33-21-01.
4. A metal license tag with the number of the license issued shall be posted in a conspicuous place on the left side of the servicing unit.
5. Every vehicle used for pumping purposes shall be equipped with a watertight tank so that there will be no spillage on private premises or on highways or roads.
6. All portable receptacles used for transporting liquid or solid waste shall be watertight, equipped with tight-fitting lids, and cleaned daily.
7. All pumps and hose lines shall be maintained so as to prevent leakage.
8. All waste material shall be disposed of in such a place and in such a manner as will not constitute a nuisance or a menace to public health.
9. Waste material collected by a pumper shall not be discharged into ditches, watercourses, lakes, ponds, tidewater, or at any point where it can pollute any water supply, bathing area, or shellfish growing area. It shall not be deposited on the surface of the ground within one thousand feet [304.8 meters] of any residence or public road.

CHAPTER 9 Vents

905 Vent Pipe Grades and Connections

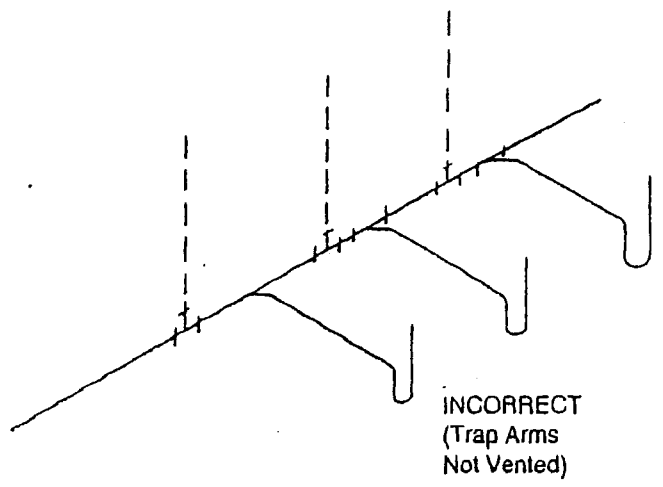
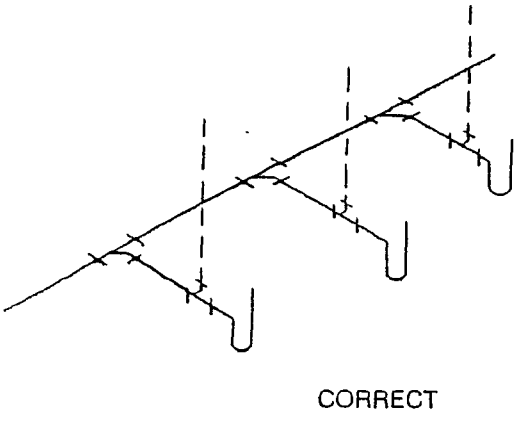
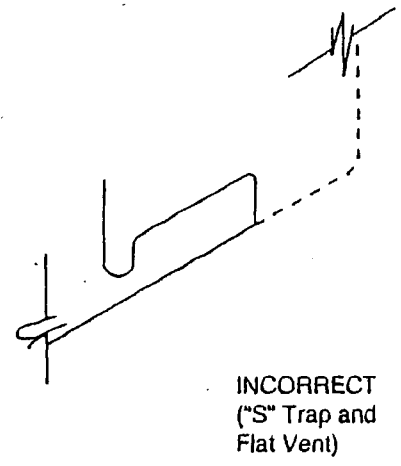
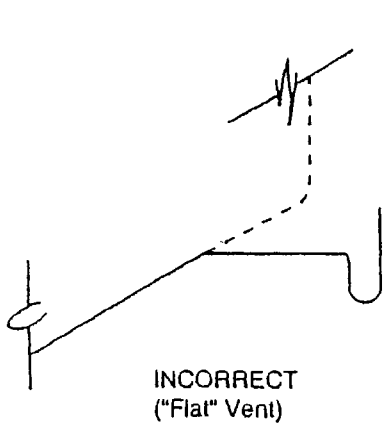
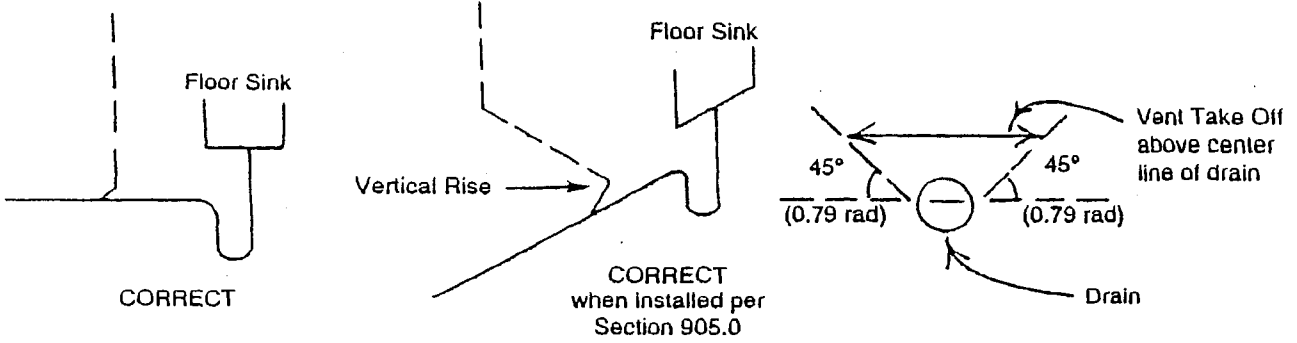

Examples of Correct and Incorrect Venting

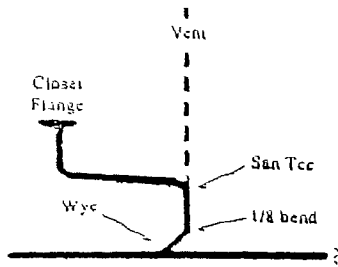

(a)
Elevation View

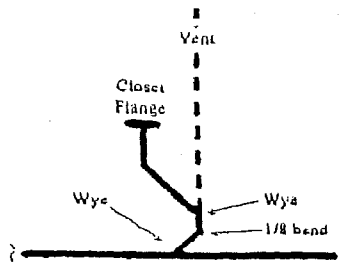

(b)
Elevation View

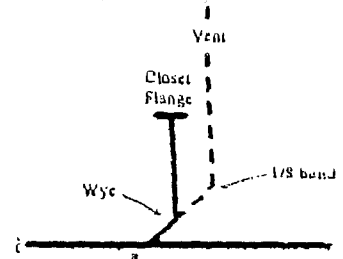

(c)
Elevation View

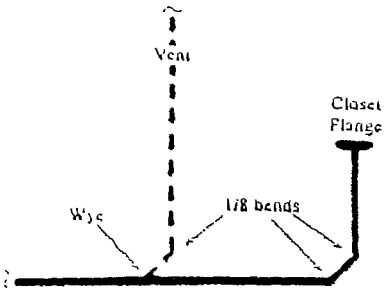

(d)
Elevation View

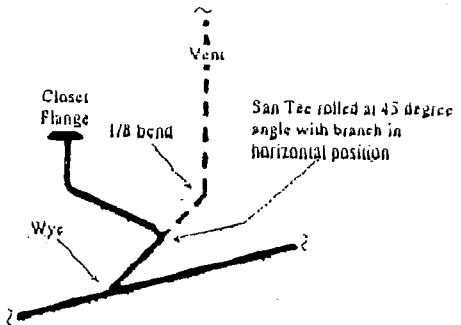

(e)
Isometric View

Water Closet Rough-In Methods, Maintaining Vertically Rising Vents

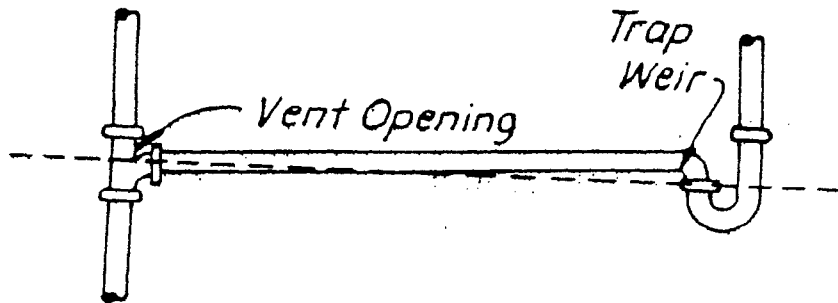
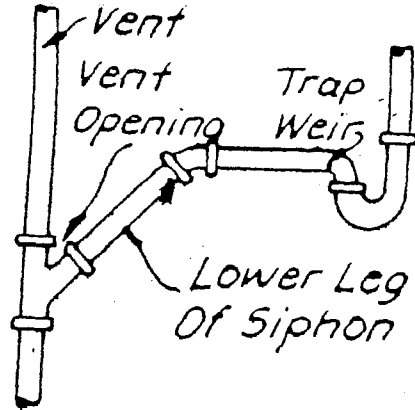
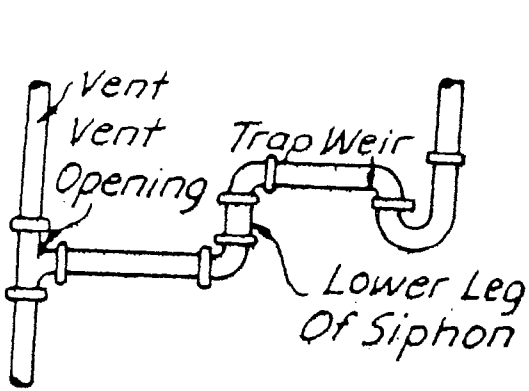

TYPICAL "S" TRAPS

908.2 Horizontal Venting for Bathroom Groups

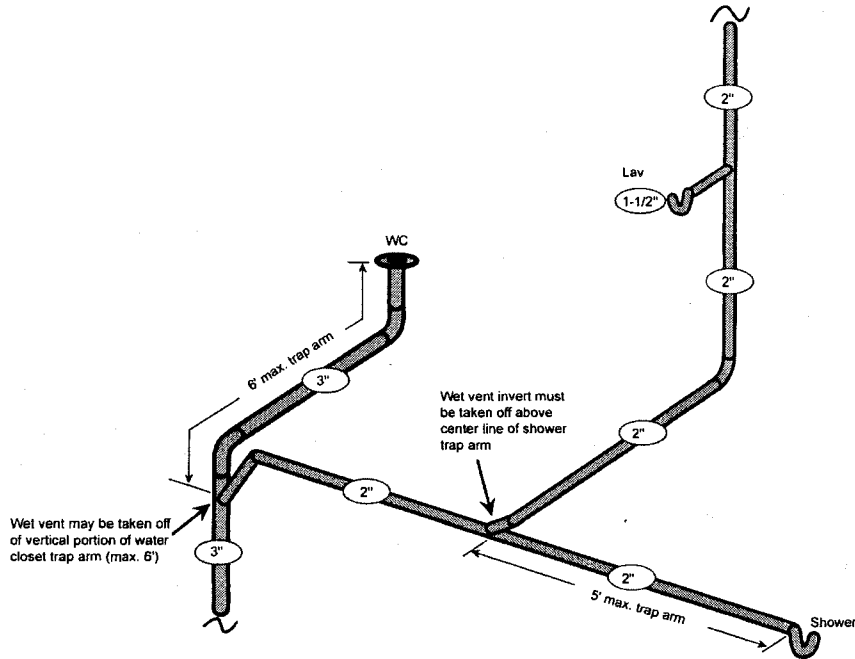
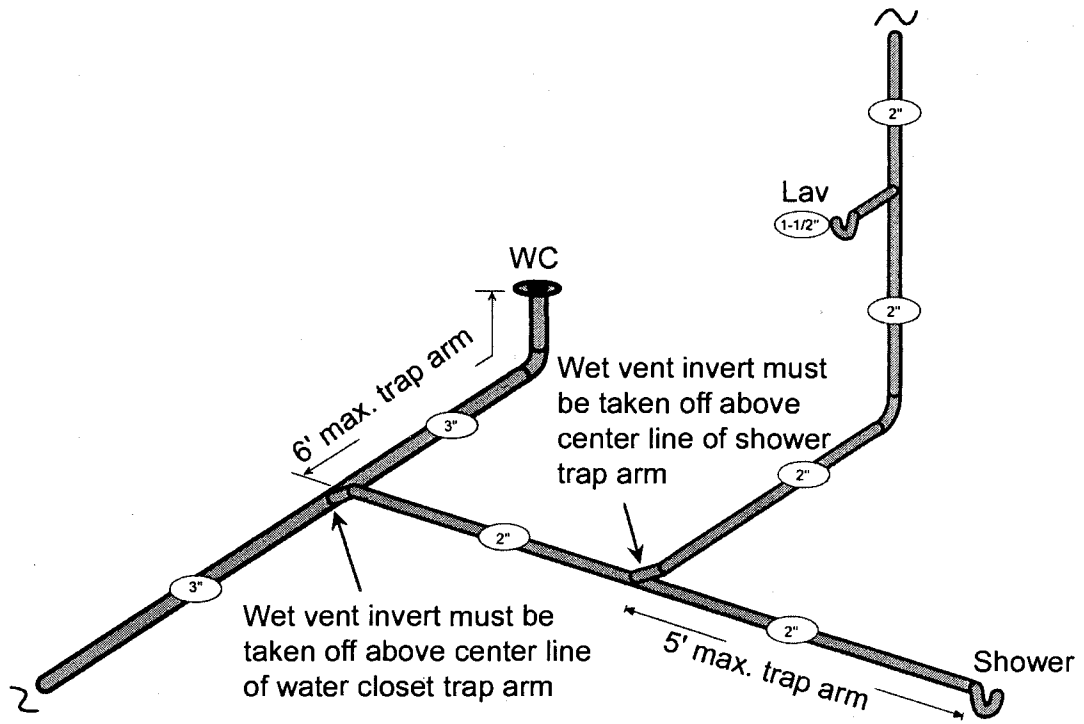

908.2.2 Double Bathtubs Bathtub/Shower Combinations, Shower Stalls and Lavatories

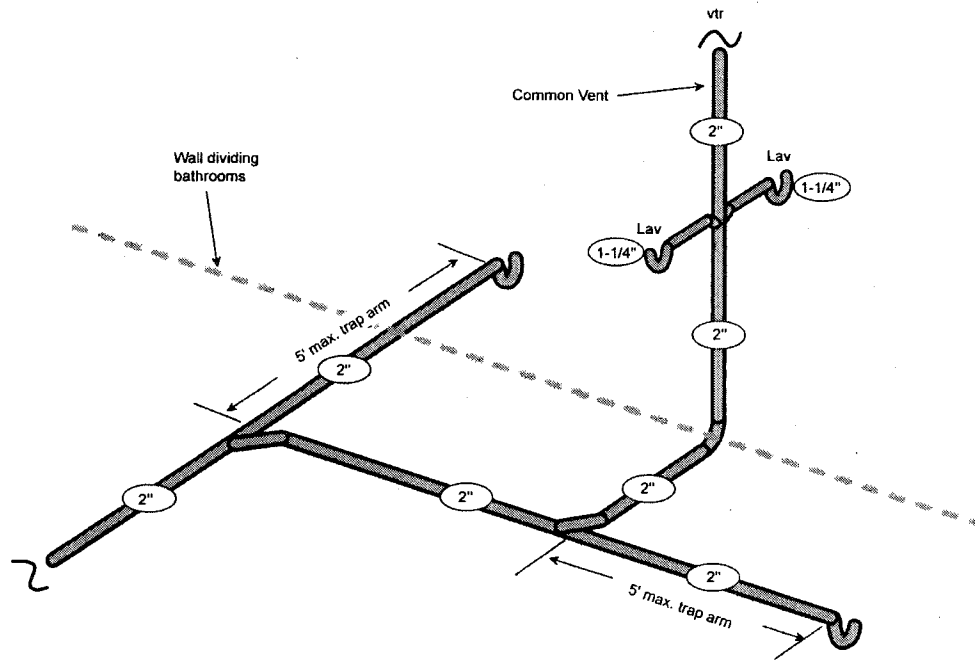

909 Special Venting for Island Fixtures

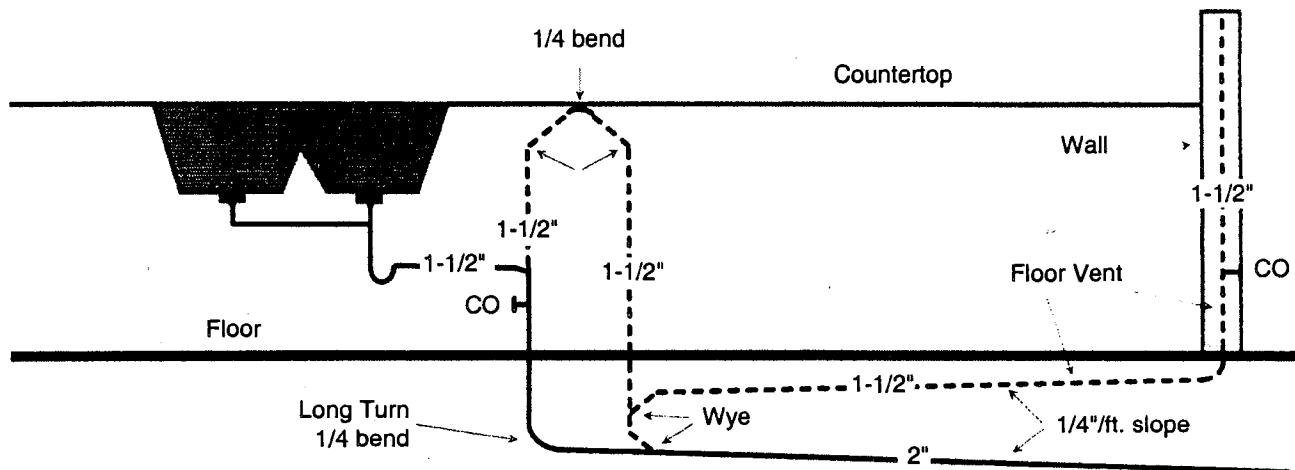

910 Combination Waste and Vents System

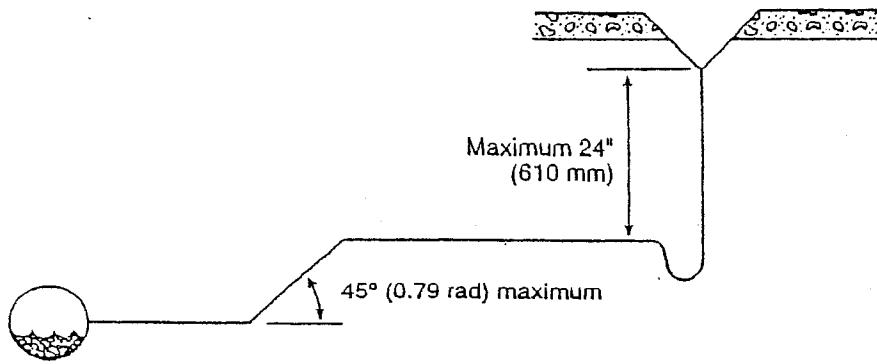
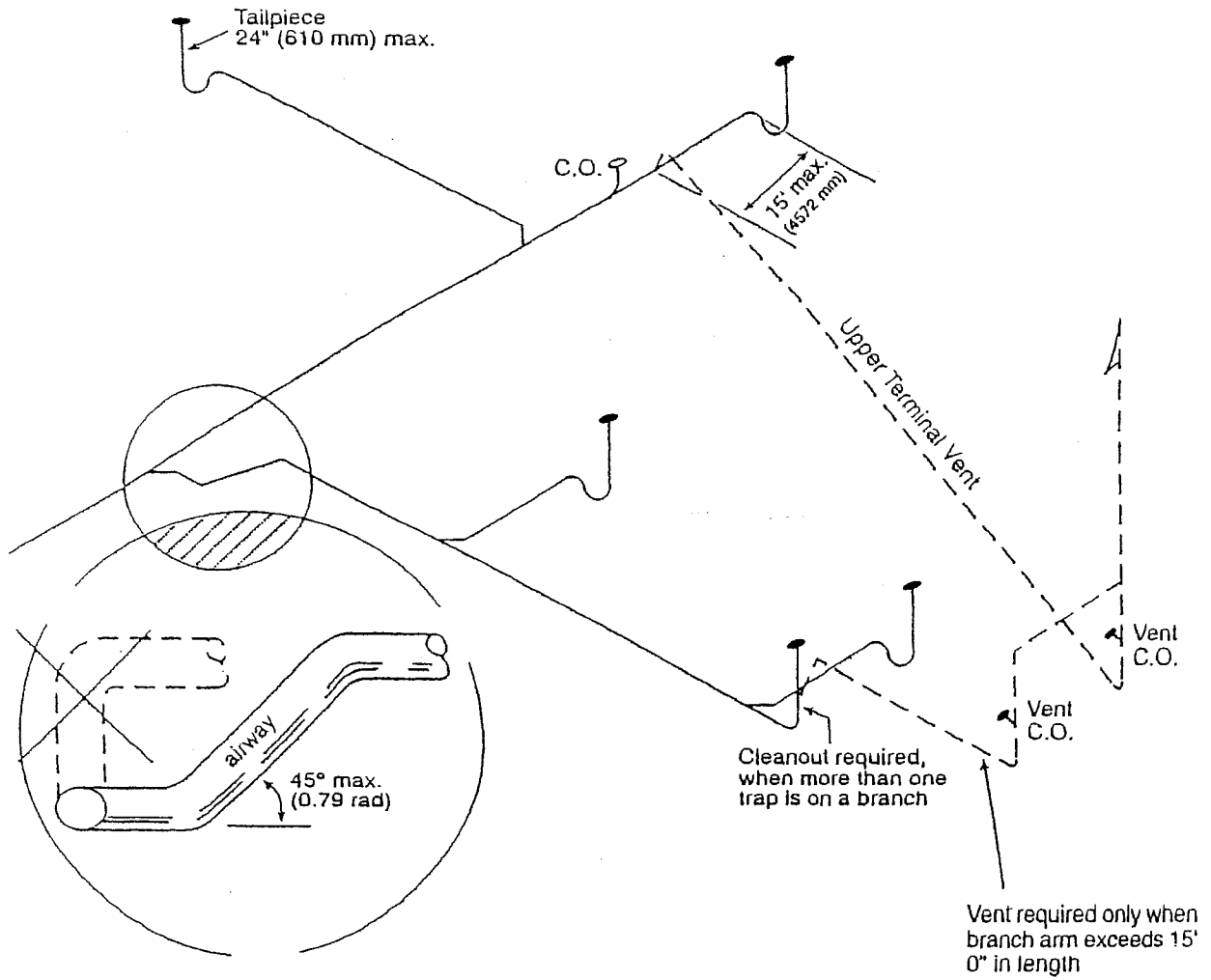

Typical Tailpiece and Branch

Chapter 10 Traps and Interceptors

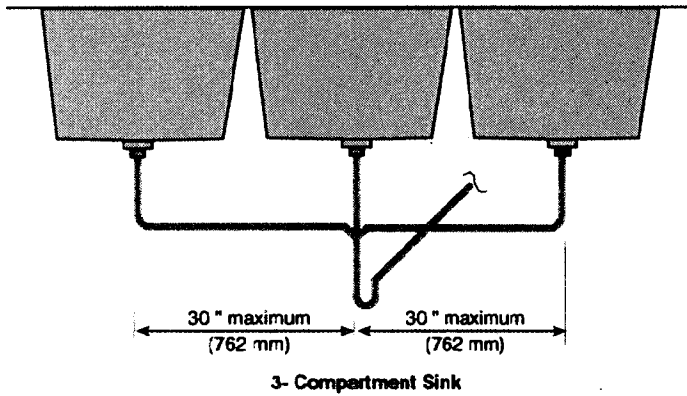

1001.2
Three Compartment Sink on One Trap

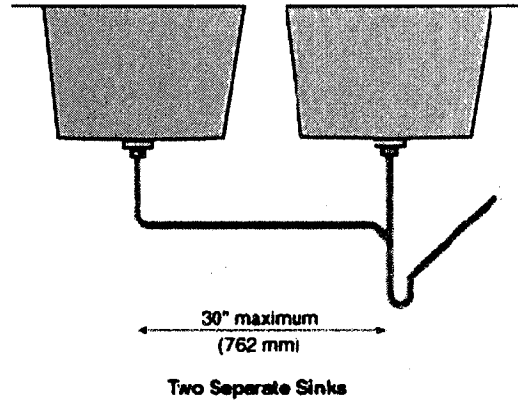

1001.2
Two Fixtures on One Trap – Prohibited if over 30 inch center to center or if overflow rim not at same level

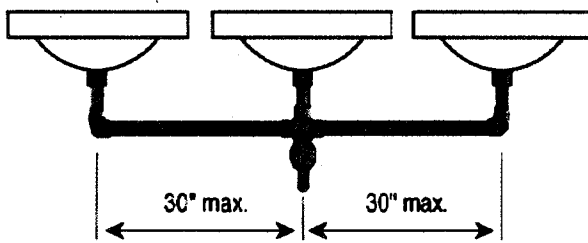

1001.2
Lavs in Sets on One Trap

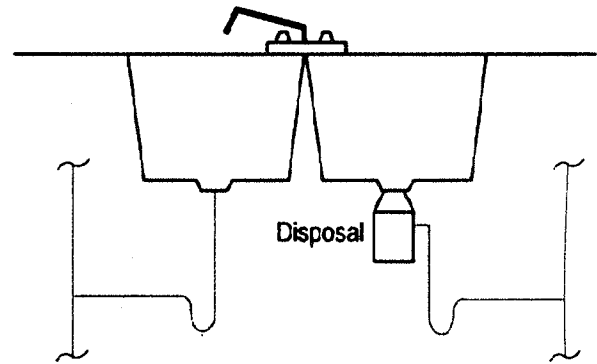

1001.3
Separate Drainage Connection for Commercial Garbage Disposal

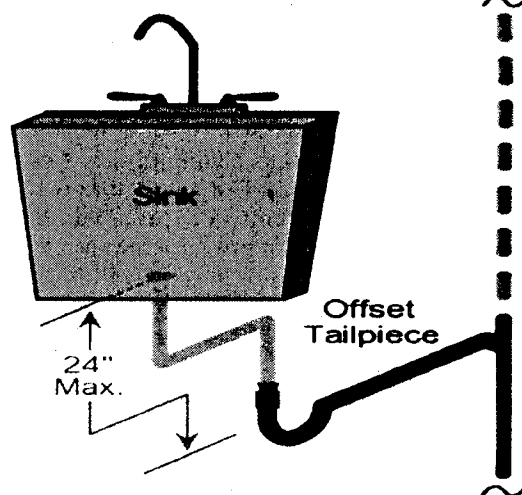
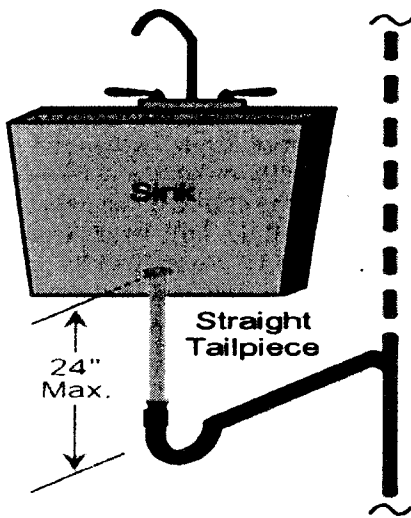

Section 1001.4 does not prohibit an offset in a tailpiece.

1001.4
Length of Tailpiece

1014. Grease Interceptors for Commercial Kitchens.

The volume of the interceptor shall be determined by using Table 10-3. If drainage fixture units (DFUs) are not known, the interceptor shall be sized based on the maximum DFUs allowed for the pipe size connected to the inlet of the interceptor. Refer to Table 7-5, Drainage Piping Horizontal.

**Table 10-3
Gravity Grease Interceptor Sizing**

DFUs	Interceptor Volume
8	500 gallons
21	750 gallons
35	1,000 gallons
90	1,250 gallons
172	1,500 gallons
216	2,000 gallons
307	2,500 gallons
342	3,000 gallons
428	4,000 gallons
576	5,000 gallons
720	7,500 gallons
2112	10,000 gallons
2640	15,000 gallons

**Gravity Grease
Interceptor Sizing Example:**

Given: A restaurant with the following fixtures and equipment. One food preparation sink, three floor drains – one in the food prep area, one in the grill area, and one receiving the indirect waste from the ice machine, a mop sink, a dishwasher with a maximum discharge flow rate of 20 gpm discharging into a dedicated receptor; and two public restrooms, each with one water closet and one lavatory.

Kitchen Drain Line DFU Count (from Table 7-3):

3 floor drains @ 2DFUs each	=	6 DFUs
Mop sink @ 3DFU's each	=	3 DFUs
Food prep sink @ 3DFUs each	=	3 DFUs
Dishwasher @ 4DFUs (Table 7-4)	=	4 DFUs
Total	=	16 DFUs

Using Table 10-3, the grease interceptor will be sized at 750 gallons.

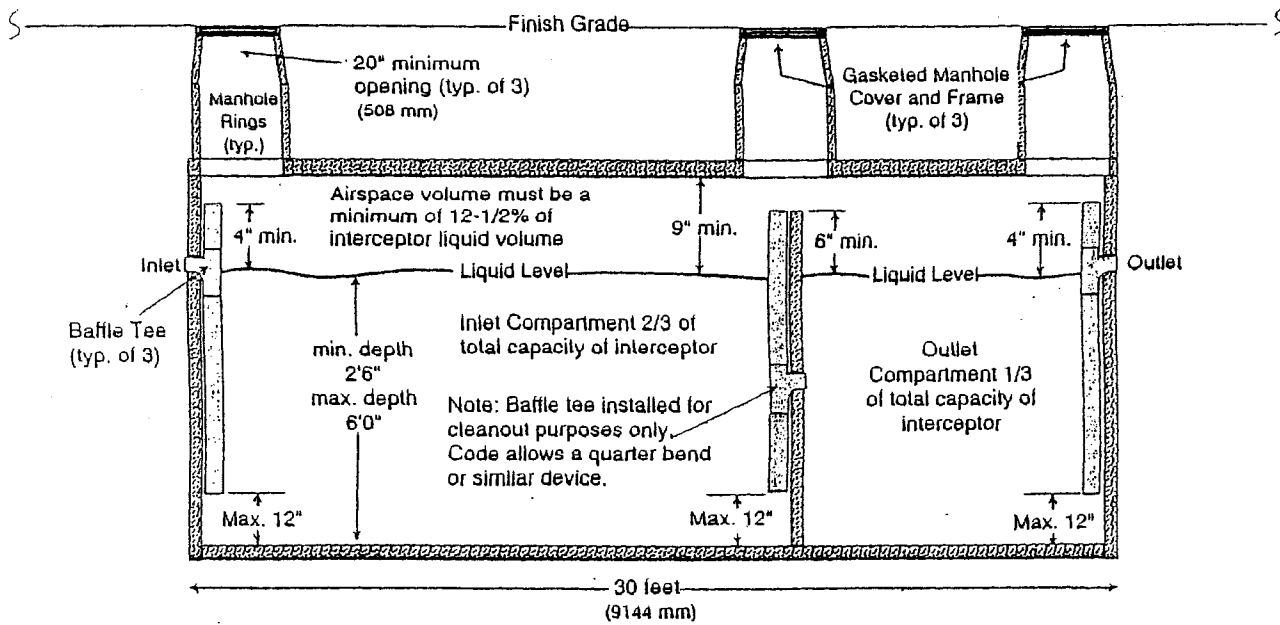

Grease and/or Garbage Interceptor

SUGGESTED DESIGNS OF INTERCEPTORS

SAND INTERCEPTOR

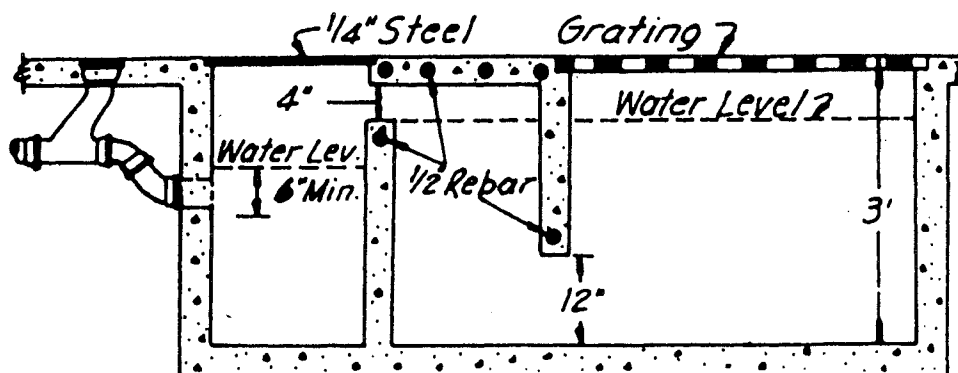

COMBINATION SAND & OIL INTERCEPTOR

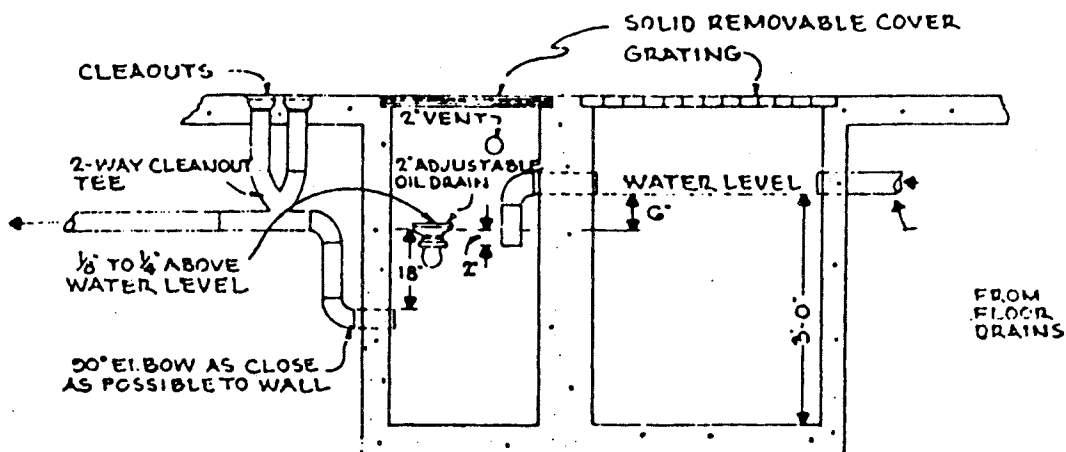

SECTION

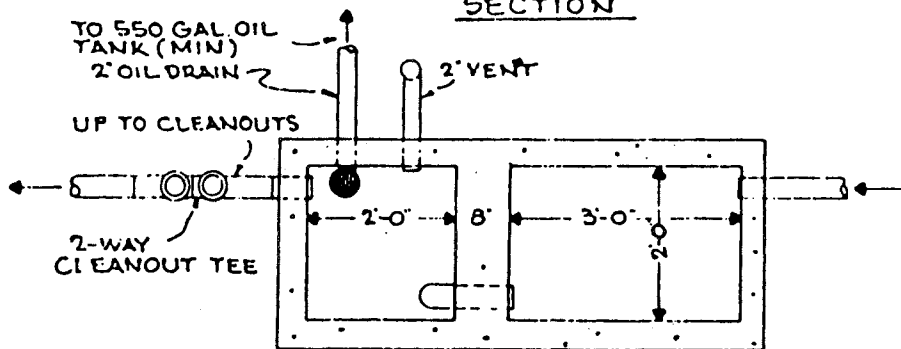

PLAN VIEW

If "S" is 4 1/4 inches, and "T" is 1 1/2 inches What is the Length of Pipe "U"?

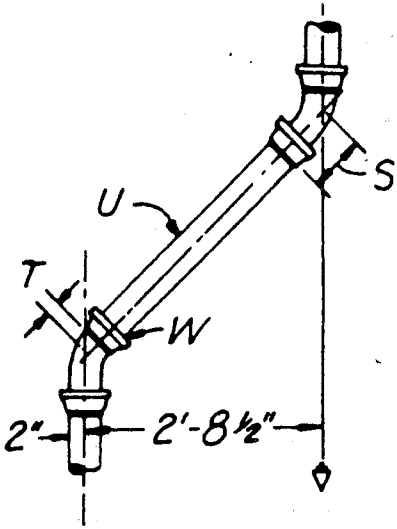

$$\begin{array}{r}
 2'-8\frac{1}{2}'' = 32.50 \\
 \times 1.414 \\
 \hline
 13000 \\
 3250 \\
 \hline
 13000 \\
 3250 \\
 \hline
 45.95500 \\
 \text{or } 45.96''
 \end{array}
 \qquad
 \begin{array}{r}
 S = 4\frac{1}{4}'' \\
 T = 1\frac{1}{2}'' \\
 \hline
 5\frac{3}{4}'' = 5.75'' \\
 \\
 45.96'' \\
 - 5.75 \\
 \hline
 40.21'' = 3'-4\frac{1}{4}''
 \end{array}$$

For offsets that are not greater than 3 feet, the following is a good rule for 45-degree offsets, but not close enough for long offsets. Add to the distance between the two parallel lines of pipe, 5 inches for each foot of such distance, and at the same rate for fractional parts of a foot. This would mean the addition of 5/12 of an inch for each inch. To be more exact, add 13/32 of an inch to each inch of distance between the two lines of pipe.

To find the pressure in pounds per square inch at the base of a column of water — multiply the head or height in feet by .434.

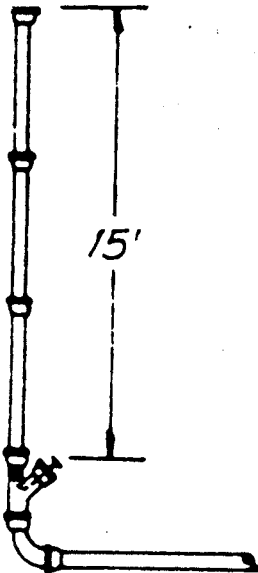

EXAMPLE

$$15' \times 434 = 6510 \text{ lbs.}$$

Or 6 1/2 lbs.

$$\begin{array}{r}
 434 \\
 \times 15' \\
 \hline
 2170 \\
 434 \\
 \hline
 6510
 \end{array}$$

To find the volume of a rectangular tank multiply length X width X height.

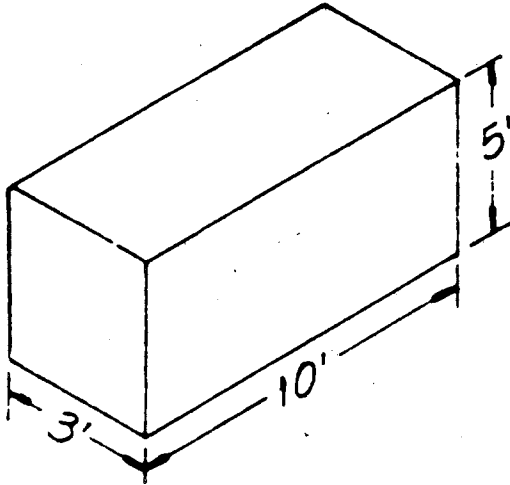

EXAMPLE

$10' \times 3' \times 5' = 150 \text{ CU Ft.}$

$$\begin{array}{r} 10' \\ \times 3' \\ \hline 30' \\ \times 5' \\ \hline 150 \end{array} \qquad \begin{array}{r} 150 \\ \times 7.48 \\ \hline 1200 \\ 600 \\ \hline 1050 \end{array}$$

1122.00 GALS.

To find the Volume in U.S. Gallons, Multiply the number of Cubic feet X 7.48

If Dimensions are given in inches Divide the number of Cubic inches by 231

7.48 GALS = 1 CU Ft.

231 CU. Inches = 1 GAL

To find the volume of a cylindrical tank multiply $R^2 \times 3.1416 \times \text{height}$, or $D^2 \times .7854 \times \text{height}$.

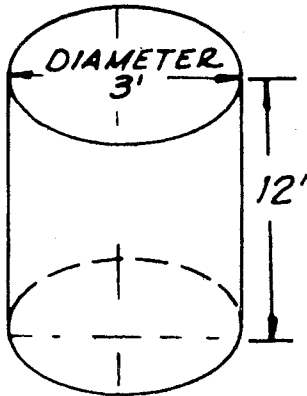

EXAMPLE

$3' \times 3' \times .7854 \times 12' = 84.8232 \text{ CU. Ft.}$

$$\begin{array}{r} .7854 \\ \times 9' \\ \hline 7.0686 \\ \times 12' \\ \hline 141372 \\ 70686 \\ \hline 84.8232 \text{ CU. Ft.} \end{array}$$

To find the Volume in U.S. Gallons, Multiply the number of Cubic feet by 7.48

If Dimensions are given in inches Divide the number of Cubic inches by 231

7.48 GALS = 1 CU. Ft.

231 CU. In. = 1 GAL.

$$\begin{array}{r} 84.8232 \text{ CU. Ft.} \\ \times 7.48 \\ \hline 6785856 \\ 3392928 \\ 5937624 \\ \hline 634.477536 \text{ GALS.} \\ \text{Or } 634\frac{1}{2} \text{ GALS.} \end{array}$$

To Find the Cubic Contents of Any Length of Pipe of Any Size. — First find the cubic contents of one foot of the pipe, then multiply that amount by the number of feet of pipe. If these dimensions are in inches, the result will be cubic inches. If the result desired is gallons, as it generally will be, divide the result in cubic inches by 231, there being 231 cubic inches in one gallon.

EXAMPLE How many Gallons will a 3/4" Pipe 50' Long Contain?

$\begin{array}{r} .75 \\ \times .75 \\ \hline 375 \\ 525 \\ \hline .5625 \\ \times .7854 \\ \hline 22500 \\ 28125 \\ 45000 \\ 39375 \\ \hline .44178750 \end{array}$	$\begin{array}{r} .4417875 \\ \times 12 \\ \hline 8835750 \\ 4417875 \\ \hline 5.3014500 \end{array}$	$\begin{array}{r} .022950 \\ 231 \overline{) 5.3014500} \\ \underline{462} \\ 681 \\ \underline{462} \\ 2194 \\ \underline{2079} \\ 1155 \\ \underline{1155} \\ 0 \end{array}$	<p>.022950 $\times 50$ <u>1.147500</u> GALS</p>
--	---	--	---

NOTE:
 $D^2 \times .7854 \times 12$
 $3/4" = .75$

A Short Method of Finding the Number of Gallons in a Foot of Pipe of Any Diameter, — Multiply the square of the inside diameter of the pipe by .0408.

EXAMPLE 3/4" Pipe 50 ft Long

$\begin{array}{r} 75 \\ \times 75 \\ \hline 375 \\ 525 \\ \hline 5625 \end{array}$	$\begin{array}{r} 5625 \\ \times .0408 \\ \hline 45000 \\ 225000 \\ \hline 02295000 \end{array}$	$\begin{array}{r} 02295 \\ \times 50 \\ \hline 114750 \text{ GALS.} \\ \text{Or} \\ 15/32 \text{ GALS.} \end{array}$
--	--	--

RULE FOR ESTIMATING THE PITCH OF A PIPE. Divide the total drop or fall of the pipe, measured in inches, by the horizontal distance between the two ends of the pipe, measured in feet. The result will give the pitch per feet in fractions of an inch.